

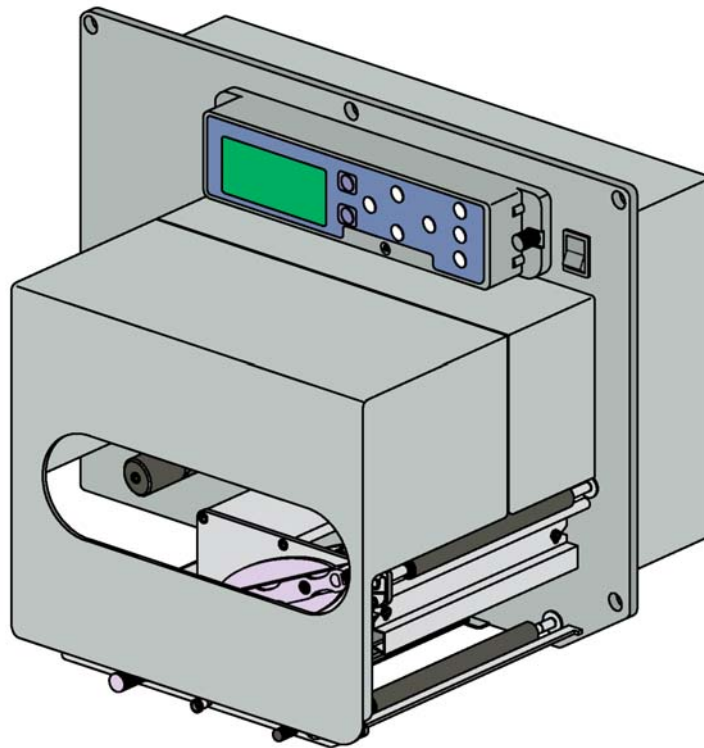

DCS & Labeling Worldwide

**Lt408
PRINT ENGINE**



OPERATOR MANUAL

SATO America, Inc.

10350A Nations Ford Road
Charlotte, NC 28273

Main Phone: (704) 644.1650

Technical Support Hotline: (704) 644.1660

Technical Support Fax: (704) 644.1661

E-Mail: satosales@satoamerica.com

technicalsupport@satoamerica.com

www.satoamerica.com

WARNING

THE EQUIPMENT REFERENCED IN THIS DOCUMENT COMPLIES WITH THE REQUIREMENTS IN PART 15 OF FCC RULES FOR A CLASS B COMPUTING DEVICE. OPERATION OF THIS EQUIPMENT IN A RESIDENTIAL AREA MAY CAUSE UNACCEPTABLE INTERFERENCE TO RADIO AND TV RECEPTION.

TABLE OF CONTENTS

INTRODUCTION

About This Manual	1-2
General Description	1-3
Control Features	1-5

TECHNICAL DATA

Physical Characteristics	2-2
Power	2-2
Environmental	2-2
Processing	2-2
Command	2-2
Interface Modules	2-2
Regulatory Approvals	2-2
Sensing	2-3
Print	2-3
Media	2-3
Ribbon	2-3
Character Font Capabilities	2-4
Barcode Capabilities	2-5

INSTALLATION

Unpacking & Parts Identification	3-2
Printer Installation	3-3
Site Location	3-3
Installation Requirements	3-3
Cable Connection	3-4
Media Selection	3-5
Ribbon Loading	3-5
Media Loading	3-6
Operational Mode Selection	3-7
Interface Selection	3-8
RS232C High-Speed Serial Interface	3-8
IEEE1284 Parallel Interface	3-11
Universal Serial BUS (USB) Adapter	3-12
Local Area Network (LAN) Ethernet	3-12
802.11b Wireless	3-13
All Interfaces	3-16
Accessories Installation	3-23
Interface Installation	3-23

PRINTER CONFIGURATION

Printer Configuration	4-2
Configuration Modes	4-3
User Mode	4-3
Advanced Mode	4-4
Parallel Interface Setup Mode	4-5
Serial Interface Setup Mode	4-6
LAN Interface Setup Mode	4-7
USB Interface Setup Mode	4-8
Centronics Interface Setup Mode	4-9
Service Mode	4-10
Factory Mode	4-11
Work Shift Mode	4-12
Hidden Mode	4-13
Download Mode	4-14
Boot Download Mode	4-15
Print Cancel Mode	4-16
Default Settings Mode	4-17
Test Print Mode	4-18
Hex Dump Mode	4-19
Menu Definition Tables	4-20

TROUBLESHOOTING

Error Signal Troubleshooting	5-2
Warning Signal Troubleshooting	5-5
Troubleshooting Table	5-6
Interface Troubleshooting	5-8
Parallel Interface	5-8
RS232 Serial Interface	5-8
Universal Serial Bus (USB) Interface	5-8
LAN Ethernet Interface	5-9
Wireless LAN Interface	5-9
Centronics Interface	5-9
Test Print Troubleshooting	5-10
Hex Dump Mode	5-10
Test Label Printing	5-11
Sample Test Label	5-12

MAINTENANCE

Cleaning Procedures	6-2
Replacement Procedures	6-3
Fuse	6-3
Print Head	6-3
Roller	6-4
Adjustment Procedures	6-5
Print Head Alignment	6-5
Print Head Pressure	6-6
Print Head Balance	6-7
Ribbon Guide	6-8
Label Sensor Positioning	6-9
Operational Adjustments	6-10
Volume	6-10
Pitch	6-10
Offset	6-10
Darkness	6-10

APPENDIX

Session Connect/Disconnect	7-2
Ready/Busy Timing Charts	7-3
X-On/X-Off Timing Charts	7-4
Printer Dimensions	7-5
Glossary	7-7

1

INTRODUCTION

- **About This Manual**
- **General Description**
- **Control Features**

ABOUT THIS MANUAL

This manual is laid out consistent with the product discussed and provides all of the information required for printer maintenance and repair by SATO approved personnel. For the repair technician, this manual is intended to compliment, and to be used as an extension of, owner/operator literature.

This manual also incorporates the use of special information boxes. Examples of these boxes and the type of information provided in each, are below.

WARNING: PROVIDES INFORMATION THAT, IF UNHEEDED, MAY RESULT IN PERSONAL INJURY.

CAUTION: PROVIDES INFORMATION THAT, IF UNHEEDED, MAY RESULT IN EQUIPMENT DAMAGE.

ATTENTION: Provides information that is deemed of special importance but will not result in personal injury or product damage if unheeded.

NOTE: Provides helpful hints to assist in performing the tasks at hand.

LCD DISPLAY: Provides the specific display that should be visible on the LCD at that point.

A comprehensive Table Of Contents provided at the front of this manual facilitates rapid movement within. The contents identify the different Units, Chapters, and some Sections. Each references the page number of their commencement.

The pages of this manual have embedded headers and footers to assist the user in identifying his or her exact position within the manual. The header provides the unit number followed by its name. The footer identifies the product on the left, the page number in the center, and the manual's part number to the right side of the page.

Page enumeration is two-part with each separated by a hyphen. The first character set references the Unit and the second identifies the page number within that unit. Page numbers begin with the numeral one (1) at the beginning of a new unit and ascend sequentially.

GENERAL DESCRIPTION

The SATO Lt408, OEM print engine has been designed and manufactured to meet the needs of the entry-level print apply market. The entry-level market can be generally defined as small to mid-sized manufacturers with low throughput, light-duty applications. These applications do not require the feature set found on standard OEM print engines that usually make capital investment unjustifiable. The Lt408 offers this market the opportunity to automate the labeling function with a system specified for their requirements and priced within their reach.

The Lt408 follows the SATO OEM print engine concept. The print engine, when integrated with an applicator system provides low-throughput, light-duty applications with automated, yet affordable, print/apply labeling solutions. Because the OEM print engine is a single-piece module, it can be easily and quickly removed for off-line servicing or for complete module replacement. Like all SATO OEM print engines, the Lt408 includes an applicator interface port to provide the required synchronization and messaging between the printer and the applicator.

When specified for suitable applications, the SATO Lt408 print engine is designed to provide years of reliable labeling operations.

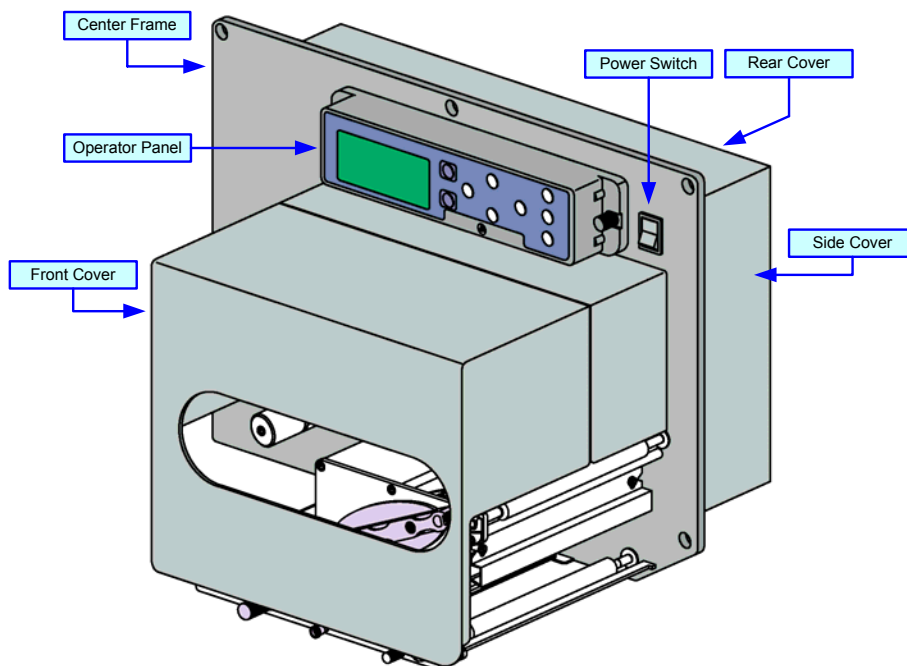

Figure 1-1a, Primary Components

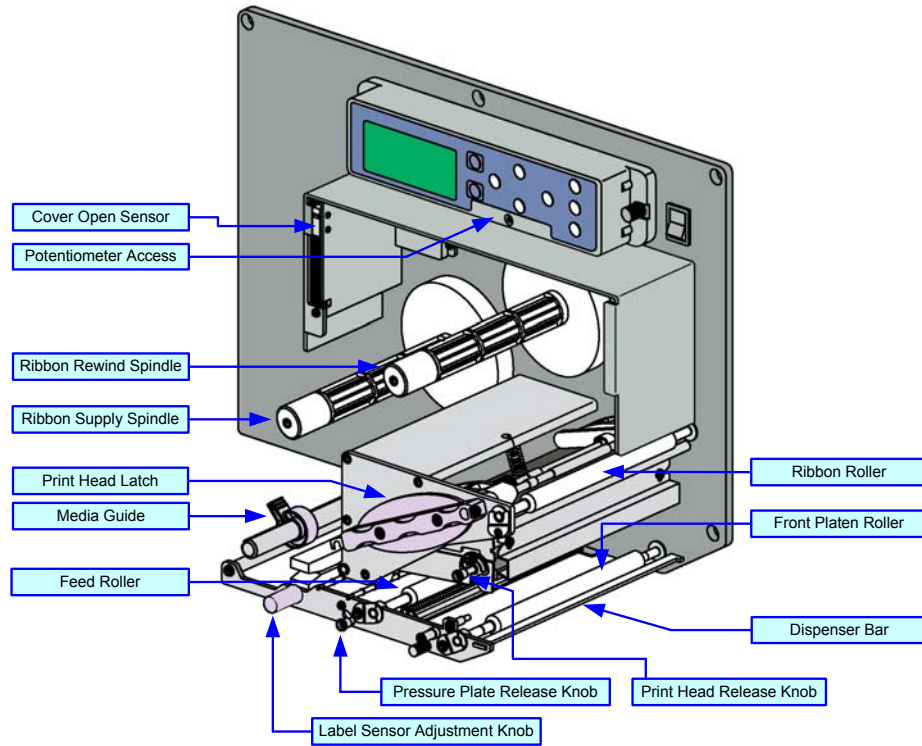

Figure 1-1b, Primary Components

CONTROL FEATURES

This chapter identifies the interactive control features of the printer. These functions are defined generally here. More specific explanations will be found throughout this manual on how to use them.

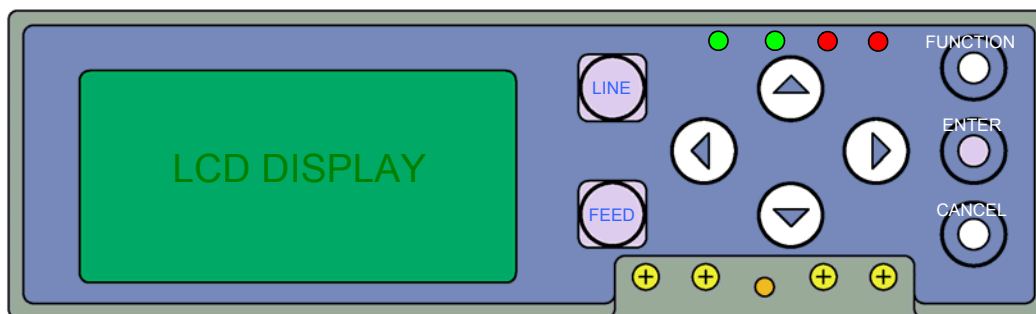

Figure 1-2, Operator Panel

OPERATOR PANEL FEATURES	
LED	DEFINITION
POWER	Illuminates green when the printer is powered on. Terminates when powered off.
ONLINE	Illuminates green when the printer is in an online state. Terminates when the printer goes offline.
LABEL	Off = Normal state. Red Constant = When a Label Error has occurred.
RIBBON	Off = Normal state. Red Flashing = Ribbon supply is low. Red Constant = When a Ribbon Error has occurred.
KEYS	DEFINITION
LINE	Moves the printer from an online to offline state and vice-versa. Has other special functions as identified in flow charts through this manual where applicable.
FEED	Advances the label media when pressed. Has other special functions as identified in flow charts through this manual where applicable.
FUNCTION	Pressing steps the LCD back to a previous menu. Has other special functions as identified in flow charts through this manual where applicable.
ENTER	Used to select a menu option and to advance the menu screen accordingly. Has other special functions as identified in flow charts throughout this manual where applicable.
CANCEL	Pressing steps the LCD back to a previous menu. Has other special functions as identified in flow charts through this manual where applicable.
ARROWS	Allows the operator to scroll through various menus and menu options. Has other special functions as identified in flow charts through this manual where applicable.
POTENTIOMETERS	DEFINITION
VOLUME	Allows volume control of the printer's audible alarm.
PITCH	For adjusting the print position.
OFFSET	Adjusts the peel or dispense stop position.
DARKNESS	Adjusts print density resulting in a lighter or darker image.

2

TECHNICAL DATA

- **Physical Characteristics**
- **Power**
- **Enviromental**
- **Processing**
- **Print**
- **Media**
- **Ribbon**
- **Sensing**
- **Interface Modules**
- **Character Font Capabilities**
- **Barcode Capabilities**
- **Regulatory Approvals**

PHYSICAL CHARACTERISTICS	
Width	12.99 Inches (330 mm)
Height	10.63 Inches (270 mm)
Depth	10.67 Inches (271 mm)
Weight	21.38 Pounds (9.7 Kg)

POWER	
Input Voltage	100-240 Volts AC +/- 10%, 50/60 Hertz +/-5%
Power Consumption	180 Watts (operating)

ENVIRONMENTAL	
Operating Temperature	4 to 104°F (5° to 40°C)
Storage Temperature	-4 to 140°F (-20° to 60°C)
Storage Humidity	15 to 85% RH Non-Condensing
Operating Humidity	15 to 85% RH Non-Condensing

PROCESSING	
CPU	32 Bit RISC
Flash ROM	4 Megabytes
SDRAM	16 Megabytes
FRAM	32 Kilobytes
Receive Buffer	2.95 Megabytes

COMMAND	
Standard	SATO Barcode Printer Language (SBPL) Intelligent Command
Non-Standard	N/A

INTERFACE MODULES	
Enhanced Parallel Port	IEEE1284 (ECP Compatible)
Serial Port	RS232C (9600 to 57,600 bps) RS422/485 (9600 to 57600 bps)
Universal Serial Bus	USB Adapter (12 Mbps)
LAN	10BASE-T/100BASE-TX Automatic Switching
Ethernet (Wireless LAN)	802.11B Wireless Wi-Fi
Centronics Parallel Port	Centronics

REGULATORY	
Safety	MET, cMET, NEMKO, CCC
Radiant Noise	VCCI (Class B), FCC (Class B), EN 55022 (Class B)
Efficiency	International Energy Star

Unit 2: Technical Data

SENSING	
Gap	Adjustable
Reflective Eye-Mark	Adjustable
Ribbon Near End	Enable/Disable
Media Out	Constant
Cover Open	Constant

PRINT	
Method	Direct Thermal / Thermal Transfer
Maximum Speed (selectable)	2, 3, 4, 5, 6 Inches Per Second (50.8-152.4 mm)
Print Module (dot size)	.0049 Inches (.125 mm)
Resolution	203 Dots Per Inch (8 dpmm)
Maximum Print Width	4.10 Inches (104 mm)
Maximum Print Length	49.17 Inches (1249 mm)

MEDIA	
Width	Media Width: 1.00 to 4.41 Inches (25.4-112 mm) Media Width with Backing Paper: 1.125 to 4.53 Inches (28.6-115 mm)
Length (Pitch)	Media Length: 0.59 to 49.29 Inches (15-1252 mm) Media Length with Backing Paper: 0.71 to 49.41 Inches (18-1255 mm)
Type	Roll Eye-Mark or Gap
Thickness	0.003 to 0.010 Inches (0.08 - 0.26 mm)

RIBBON	
Width	Minimum: 0.98 Inches (25 mm) Maximum: 4.37 Inches (111 mm)
Length	1476 Feet (450 M)
Wound	Face In / Face Out.
Roll Diameter	3.34 Inches (85 mm)
Core Diameter	1 Inch (25.4 mm)

CHARACTER FONT CAPABILITIES	
MATRIX FONTS	
XU	5 dots W x 9 dots H (Helvetica)
XS	17 dots W x 17 dots H (Univers Condensed Bold)
XM	24 dots W x 24 dots H (Univers Condensed Bold)
OA Font (OCR-A)	15 dots W x 22 dots H
OB Font (OCR-B)	20 dots W x 24 dots H
AUTO SMOOTHING FONTS	
XB	48 dots W x 48 dots H (Univers Condensed Bold)
XL	48 dots W x 48 dots H (Sans Serif)
VECTOR FONT	
	Proportional or Fixed Spacing Font Size 50 x 50 dots to 999 x 999 dots Helvetica, 10 Font Variations
AGFA RASTER FONTS	
A Font	CG Times, 8 to 72 pt.
B Font	CG Triumvirate, 8 to 72 pt.
DOWNLOADABLE FONTS	
	N/A
CHARACTER CONTROL	
	Expansion up to 12 x in either the X or Y coordinates. Character Pitch Control Line Space Control Journal Print Facility 0, 90, 180, and 270 Degree Rotation

BAR CODE CAPABILITIES	
Linear Bar Codes	UPC A/E JAN 8/13 EAN 8/13 Code 39 Code 93 Code 128 Interleaved 2 of 5 Industrial 2 of 5 Matrix 2 of 5 Bookland RSS-14 MSI POSTNET UCC/EAN 128 NW-7 (Codabar)
Two Dimensional	QR Code Data Matrix Maxi Code PDF417 Synthetic Symbol
Ratios	1:2, 1:3, 2:5, User definable bar widths
Bar Height	4 to 999 dots, User programmable
Rotation	0, 90, 180, and 270 Degrees
Sequential Numbering	Sequential numbering of both numerics and bar codes
Expansion Ratio of Character	Height: 1-12 times, Width: 1-12 times
Graphics	Full dot addressable graphics, SATO Hex/Binary, BMP or PCX formats
Form Overlay	Form overlay for high-speed editing of complex formats

3

INSTALLATION

- **Unpacking & Parts Identification**
- **Printer Installation**
- **Operational Mode Selection**
- **Interface Selection**
- **Accessories Installation**

UNPACKING & PARTS IDENTIFICATION

Unpack the printer as directed in the following procedure.

1. Place the shipping container (box) upright on a stable, flat surface.
2. Open the box, remove any loose items and the first layer of packing material.
3. Carefully lift the printer and accessories from the box and place them on a stable, flat surface.
4. Remove the plastic covers from the packed items and visually inspect for physical damage.
5. Ensure all components are present as dictated on the Packing List.
6. Report damaged property to the shipping carrier.

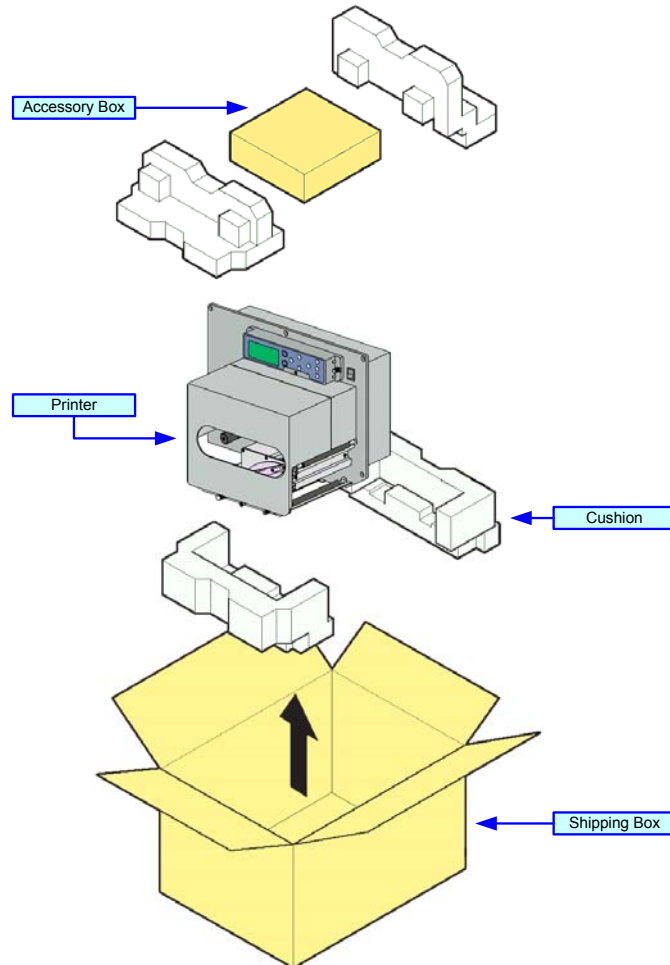

Figure 3-1, Unpacking

PRINTER INSTALLATION

This chapter provides guidance on how to station, connect, and load the printer once unpacked. Following printer setup, proceed to the next chapter for information on interface selection.

SITE LOCATION

- Stationed away from hazardous materials.
- Stationed within an enclosed structure that conforms to the printer's environmental requirements.
- Stationed within operational distance of the host based on interface specifications.
- Stationed to allow unimpeded access to the printer for operation, loading, and maintenance.

INSTALLATION REQUIREMENTS

The printer has five bores in its center frame for the purpose of mounting to a support structure. Refer to the following list of mounting requirements.

- The support structure must be firmly secured to the floor or production machinery.
- The support structure must be sturdy and stable so as to prevent unnecessary movement or vibration.
- The printer is to be mounted to the support structure using attaching hardware design to accommodate the printer's weight, as well as, the prevailing operational and environmental conditions within the facility.
- A power supply receptacle or junction box is to be properly secured within regulated proximity to the printer.
- The power supply is to be metered conducive to the printer's design requirements.
- The printer must be installed so that its output side is within the designated distance and height relative to the applicator.
- Media supply dispensers must be mounted or placed with operational distance of the printer's input side.

NOTE: Figures 3-2 and 3-3 are to be used as instructional displays only and are not to be literally interpreted as precise examples.

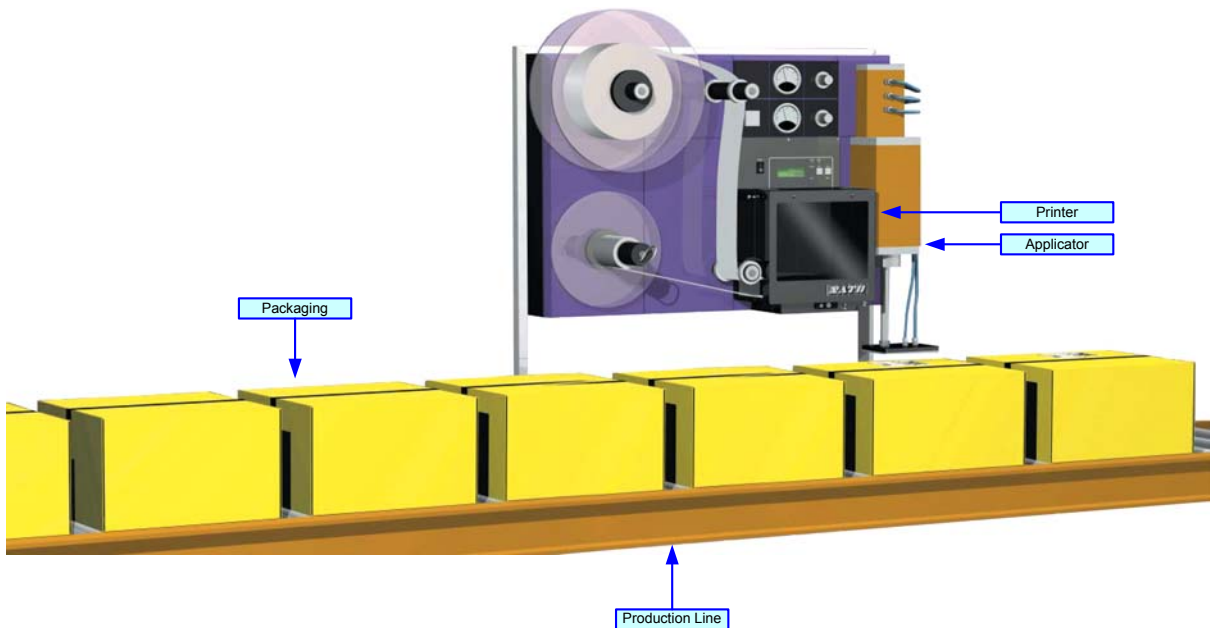

Figure 3-2, Typical Printer/Applicator Process

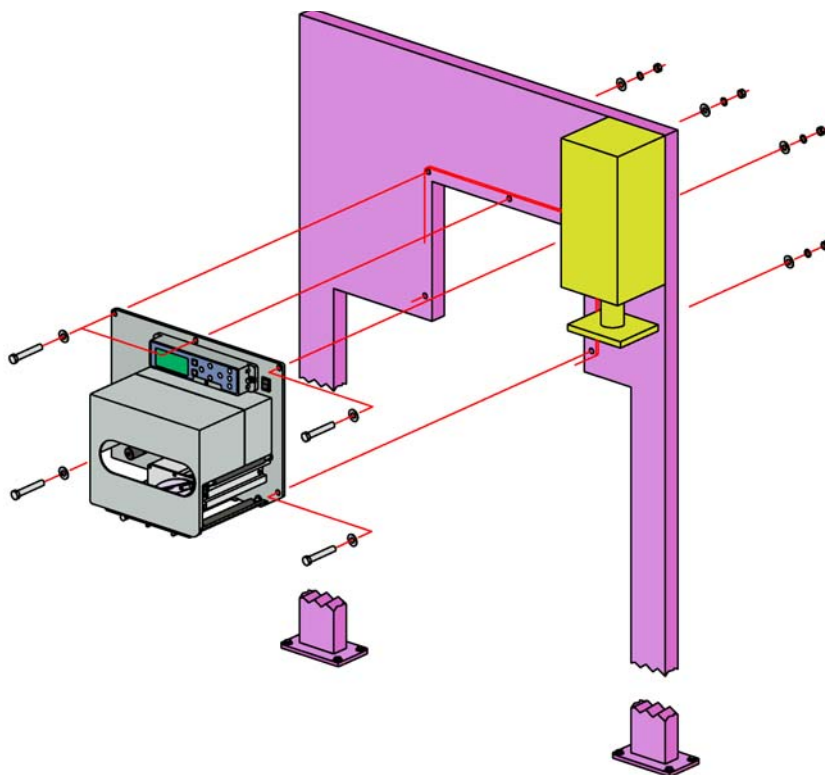

Figure 3-3, Printer Mounting

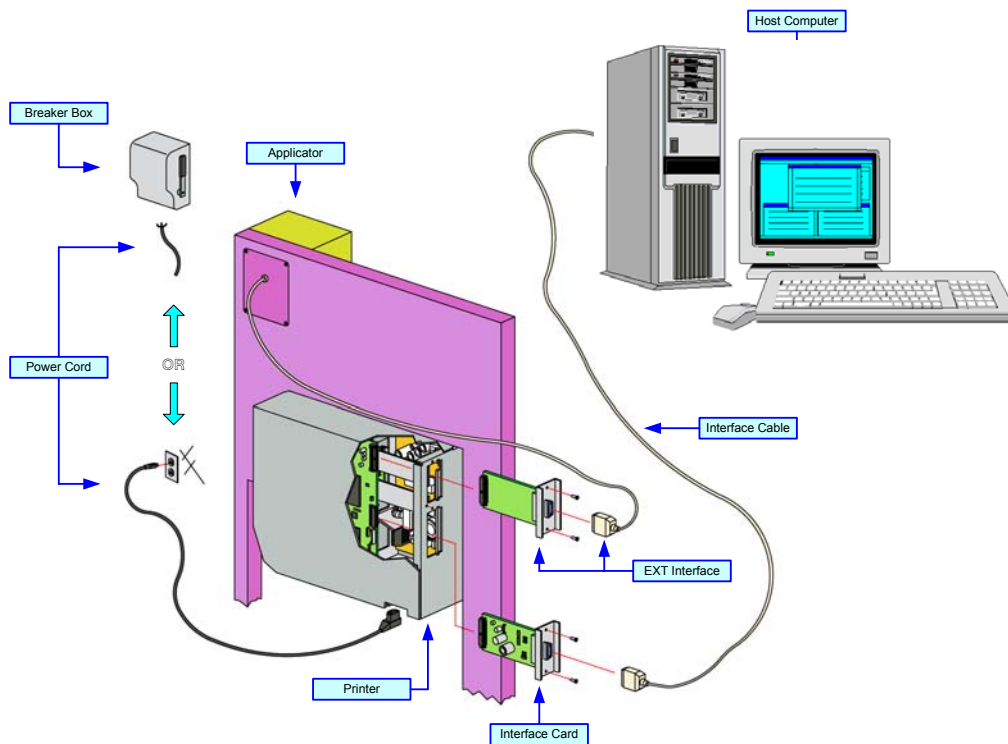

Figure 3-4, Printer Connection

ATTENTION: Figure 3-4 displays the printer interfaced with a host computer. However, the printer may also be interfaced with a PLC, keyboard, scanner, etc.

MEDIA SELECTION

The size and type of labels to be printed should have been taken into consideration before printer purchase. Ideally, the media width will be equal to, or just narrower than, the print head. Using media that does not cover the print head will allow the platen roller to tread upon its surface resulting in premature wear. The media edge will also wear a groove in the platen roller affecting print quality.

There are two types of media that may be used: thermal transfer and direct thermal. Thermal transfer media requires the use of ribbon stock for print application. In such a scenario, it is the ribbon stock (carbon paper) that contains the ink that will be transferred to the media.

Direct thermal media has thermally reactive material embedded within and is brought to the surface through heat penetration by print head contact. Only load ribbon stock into the printer if that media type is to be used.

RIBBON LOADING

To load ribbon stock, unlatch the print head and remove exhausted ribbon stock if applicable. Insert an unused ribbon roll, with ribbon core, fully onto the ribbon supply boss (left) and an empty core onto the ribbon rewind boss (right). Route the ribbon's free end around the print assembly and tape it to the blank core on the rewind boss. Rotate the core a couple of times while holding the boss stationary to take up take up slack. Refer to Figure 3-5 for visual assistance.

WARNING: AVOID PHYSICAL CONTACT WITH THE PRINT HEAD TO PREVENT BURNED FINGERS/HANDS AND COMPONENT DAMAGE.

NOTE: Properly installed ribbon stock will be oriented so that its dull, ink side is facing the printer chassis while the ribbon is dispensed and taken up on the right side of each roll. The non-ink side of the ribbon stock is the shiniest of the two surfaces.

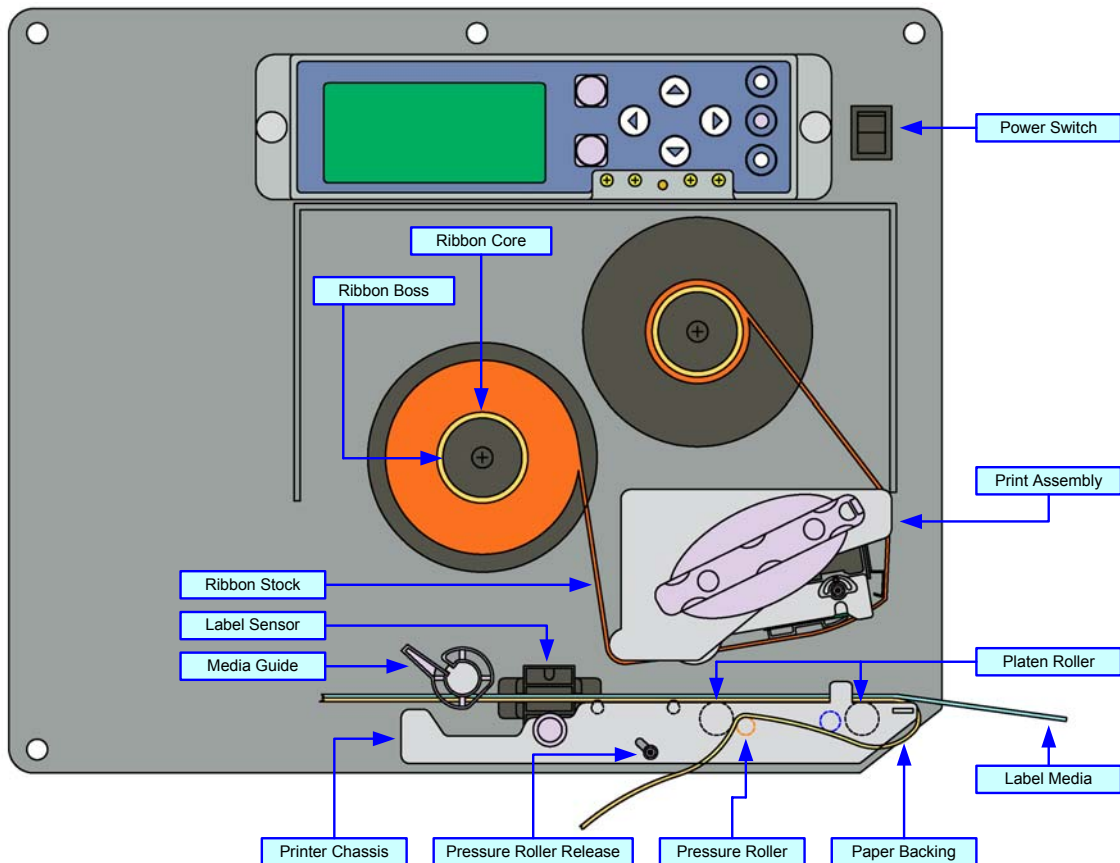

Figure 3-5, Ribbon & Media Loading

MEDIA LOADING

To load label media, unlatch the print head and remove any remnants that may exist of the prior media supply. Feed the free end of the media from the printer's left side, beneath the shaft of the media guide, between the upper and lower halves of the label sensor, across the top of all forthcoming rollers, and through to protrude six or more inches beyond the printer chassis.

Ensure the media is flush against the printer's back side (toward the center wall) and then adjust the media guide inward until it almost makes contact with the media's backing paper.

Remove all labels from the backing paper that extend beyond the printer chassis and relatch the print head.

Lift upward on the pressure roller release knob (purple) and allow the pressure roller plate to fall to a vertical position. Route the backing paper's free end around the front of the printer chassis, beneath the front platen roller and onward between the second platen roller and the pressure roller. Pull the free end of the backing paper to remove all slack while lifting the pressure plate until latched. Refer to Figures 3-5 and 3-6 for visual assistance.

WARNING: AVOID PHYSICAL CONTACT WITH THE PRINT HEAD TO PREVENT BURNED FINGERS AND HANDS.

NOTE: Properly installed label media will be oriented so that the label side is upward and the backing paper is downward resting upon the printer chassis.

NOTE: Refer to the Printer Configuration unit of this manual for media configuration instructions and the Adjustment chapter of the Maintenance unit for label sensor adjustment instructions as necessary.

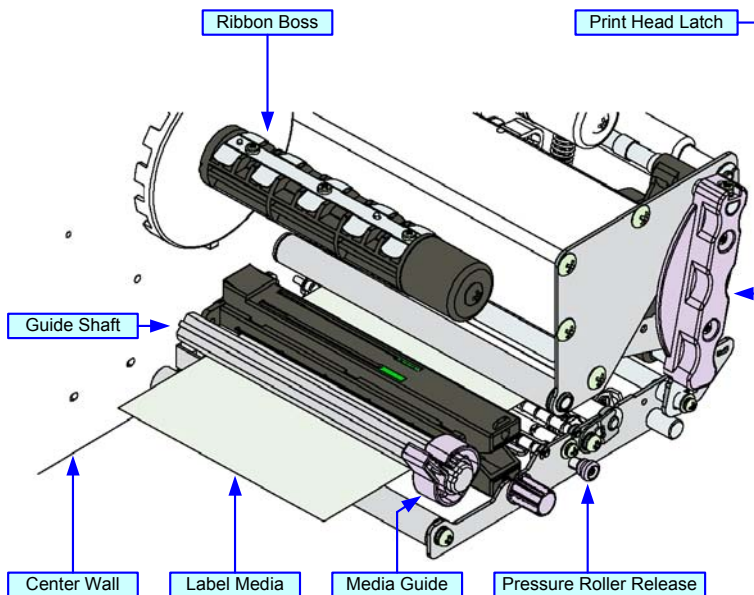

Figure 3-6, Media Loading

OPERATIONAL MODE SELECTION

There are two modes of printer operation: Dispense or Continuous. The difference between the two is the way that the label and paper backing is ejected. Before printer configuration, one must determine which mode will be used. This chapter identifies and defines the functional differences between the two.

DISPENSE MODE

With this method of operation, after printing, the printer feeds the first (outermost) label so that it is fully extended out of the printer's front for dispensing. Printing of the next label will not begin until the prior printed label has been removed. This mode of operation is specifically suited for the use of automated machinery to remove the printed and dispensed label to apply to packaging, etc.

Upon removal of the prior printed label, the printer repositions the media so that the next label in line may be printed, then prints. The before-mentioned cycle, repeats for each consecutive label.

Printer configuration for the backfeed function may be found in the Advanced Mode of the Configuration unit of this manual. Refer to the Table of Contents for the page number.

CONTINUOUS MODE

With this method of operation, the media remains in position for printing at all times. To do so, means that the previous printed label is never in proper position for dispensing and thusly, must be manually removed form the printer rather than through the application of automated machinery.

Printer configuration for Continuous mode of operation may be found in the Advanced Mode of the Configuration unit of this manual. Refer to the Table of Contents for the page number.

ATTENTION: Refer to the Printer Configuration unit of this manual to program the printer's internal memory to suit individual needs using the printer's integrated menu options. Refer to the Programming Reference document to remotely program the printer's features and functions through a host system.

INTERFACE SELECTION

This unit presents the printer interface types and their specifications. These specifications include detailed information to assist in the selection of the most appropriate method for the printer to interface with the host. The five acceptable interface methods are:

- RS232C High-Speed Serial
- IEEE1284 Parallel
- Universal Serial Bus (USB)
- Local Area network (LAN) Ethernet
- 802.11b Wireless

Following the selection of the desired interface, proceed to the next unit for instructions on how to Configure the printer for that interface type.

WARNING: NEVER CONNECT OR DISCONNECT INTERFACE CABLES (OR USE A SWITCH BOX) WITH POWER APPLIED TO EITHER THE HOST OR THE PRINTER. THIS MAY CAUSE DAMAGE TO THE INTERFACE CIRCUITRY IN THE PRINTER/HOST AND IS NOT COVERED BY WARRANTY.

NOTE: Some hosts monitor the Request-To-Send (RTS) signal (pin 4 of 25) to determine if the printer is ready to receive data. Since the printer does not generate this signal, the RTS line must be held true (high) in order to allow communication. This can be performed by connecting the RTS pin to the Clear-To-Send (CTS) signal (pin 5 of 25).

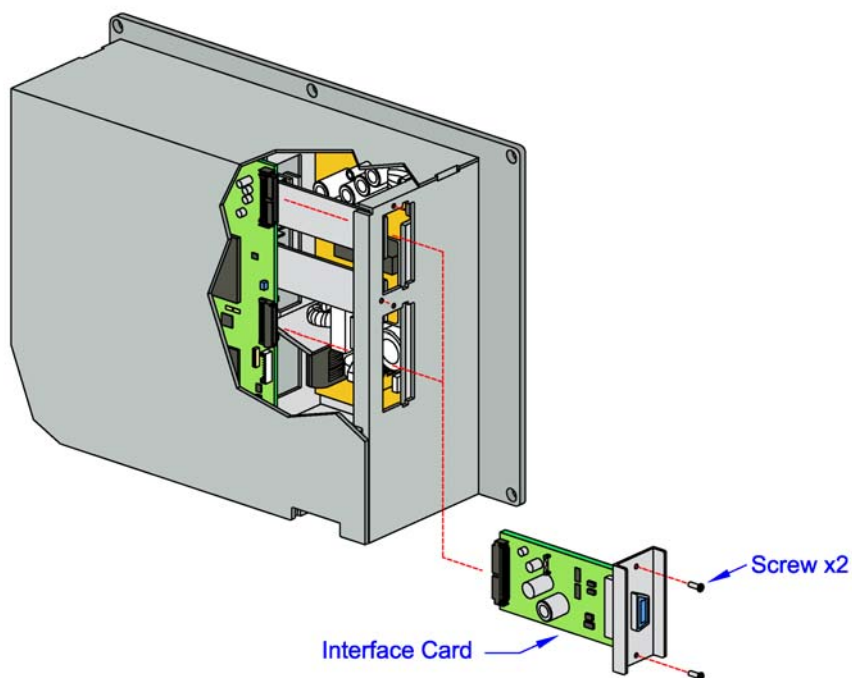

Figure 3-7, Interface Installation

RS232C HIGH-SPEED SERIAL INTERFACE

INTERFACE SPECIFICATIONS	
Asynchronous ASCII	Half-duplex communication Bi-Directional Communication
Data Transmission Rate	9600, 19200, 38400, 57600 bps
Transmission Form	Start, b1, b2, b3, b4, b5, b6, b7, b8, Stop (b8 will be omitted if using 7 bit oriented)
Data Length	7 or 8 bit (selectable)
Stop Bit	1 or 2 bit (selectable)
Parity Bit	ODD, EVEN, NONE (selectable)
Codes Used	ASC II Character Codes: 7 bits, Graphics: 8 bits
Control Codes	STX (02H), ETX (03H), ACK (06H), NAK (15H)
Connector (Printer Side)	DB-25S Male (equivalent)
Cable Connector	DB-25P Female (equivalent)
Cable Length	5 meters or less.
Signal Levels	High = +5V to +12V, Low = -5V to -12V
Protocol	Ready/Busy, X-On/X-Off, Protocol for Driver, Status4

DIPSWITCH SETTINGS				
SWITCH	COMPONENT	SETTINGS		
1	Data Bit	ON		7 Bits
		OFF		8 Bits
2 & 3	Parity	2	3	
		ON	ON	Reserved
		ON	OFF	ODD
		OFF	ON	EVEN
OFF	OFF	NONE		
4	Stop Bit	ON		2 Bits
		OFF		1 Bit
5 & 6	Baud Rate	5	6	
		ON	ON	57600 bps
		ON	OFF	38400 bps
		OFF	ON	19200 bps
OFF	OFF	9600 bps		
7 & 8	Protocol	7	8	
		ON	ON	Reserved: Status2 & 3 (when compatible mode is OFF)
		ON	OFF	Protocol for Driver, Status5
		OFF	ON	X-ON/X-OFF
OFF	OFF	Ready/Busy		

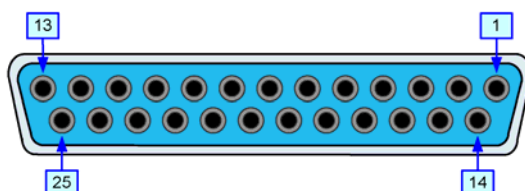

Figure 3-8, Serial Connector Pin Assignments

READY/BUSY INTERFACE SIGNALS		
PIN	DIRECTION	SIGNAL DEFINITION
1	Reference	FG (Frame Ground)
2	To Host	TD (Transmit Data) - Data from the printer to the host computer. Sends X-On/X-Off characters or status data (bi-directional protocols).
3	To Printer	RD (Receive Data) - Data to the printer from the host computer.
4	To Host	RTS (Request to Send) - Used with Ready/Busy flow control to indicate an error condition. RTS is high and remains high unless the print head is open (in this case, RTS would return to the high state after the print head is closed and the printer is placed back on-line) or an error condition occurs during printing (e.g., ribbon out, label out).
5	To Printer	CTS (Clear to Send) - When this line is high, the printer assumes that data is ready to be transmitted. The printer will not receive data when this line is low. If this line is not being used, it should be tied high (to pin 4).
6	To Printer	DSR (Data Set Ready) - When this line is high, the printer will be ready to receive data. This line must be high before data is transmitted. If this line is not being used, it should be tied high (to pin 20).
7	Reference	SG (Signal Ground)
20	To Host	DTR (Data Terminally Ready) - This signal applies to Ready/Busy flow control. The printer is ready to receive data when this pin is high. It goes low when the printer is off-line, either manually or due to an error condition, and while printing in the single job buffer mode. It will also go low when the data in the buffer reaches the buffer near full level.

READY/BUSY CABLE REQUIREMENTS					
DB9	DB25	HOST	DIRECTION	DB25	PRINTER
1	1	FG (Frame Ground)	Bi-Directional	1	FG (Frame Ground)
2	3	RD (Receive Data)	To Host	2	TD (Transmit Data)
3	2	TD (Transmit Data)	To Printer	3	RD (Receive Data)
8	5	CTS (Clear To Send)	To Printer DB9-6	4	RTS (Request To Send)
4	20	DTR (Data Terminal Ready)	To Printer DB9-4	5	DSR (Data Set Ready)
6	6	DSR* (Data Set Ready)	To Host	6	DTR (Data Terminal Ready)
5	7	SG (Signal Ground)	Bi-Directional	7	SG (Signal Ground)

** This connection at the host side of the interface would depend upon the pin that is being used as the Ready/Busy signal by the driving software. Typically, on a PC, it would be either CTS (pin5) or DSR (pin 6) on a DB-25 connector.*

X-ON/X-OFF CABLE REQUIREMENTS					
Communicates with the host to determine if the printer is ready to receive data by sending "XON" (HEX 11H) or "XOFF" (HEX 13H) code to the TD line. The single and multiple item buffers are switchable in the Interface Mode of the printer.					
DB9	DB25	HOST	DIRECTION	DB25	PRINTER
1	1	FG (Frame Ground)	Bi-Directional	1	FG (Frame Ground)
2	3	RD (Receive Data)	To Host	2	TD (Transmit Data)
3	2	TD (Transmit Data)	To Printer	3	RD (Receive Data)
5	7	SG (Signal Ground)	Bi-Directional	7	SG (Signal Ground)

NOTE: Depending on the host used, it may be required to loop CS and RS (maintaining at high-level) on the host side. For more information, refer to the host computer documentation.

IEEE1284 PARALLEL INTERFACE

The parallel interface is a plug-in module that can be installed by the user and conforms to IEEE1284 specifications. It automatically detects the IEEE1284 signals and operates in the high speed mode. If the IEEE1284 signals are not detected, it will operate in the slower standard Centronics mode. For this reason, an interface cable and host interface conforming to the IEEE1284 specification must be present to fully utilize the speed capabilities. This interface also operates bi-directionally and can report the status of the printer back to the host.

SPECIFICATIONS	
Printer Connector	AMP 57-40360 DDK (or equivalent)
Cable Connector	AMP 57-30360 DDK (or equivalent)
Cable	1.5 meter or less
Signal Level	High = +2.4V to +5.0V, Low = 0V to -0.4V
Data Stream	<ESC>A . . Job#1 . . <ESC>Z<ESC>A . . Job#n . . <ESC>Z

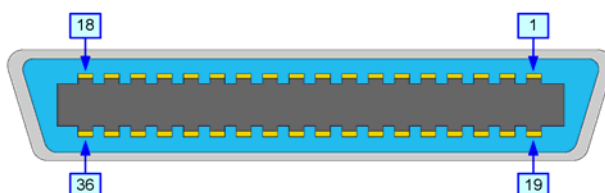

Figure 3-9, Parallel Connector Pin Assignments

PIN ASSIGNMENTS					
PIN	SIGNAL	DIRECTION	PIN	SIGNAL	DIRECTION
1	Strobe	To Printer	19	Strobe Return	Reference
2	Data 1	To Printer	20	Data 1 Return	Reference
3	Data 2	To Printer	21	Data 2 Return	Reference
4	Data 3	To Printer	22	Data 3 Return	Reference
5	Data 4	To Printer	23	Data 4 Return	Reference
6	Data 5	To Printer	24	Data 5 Return	Reference
7	Data 6	To Printer	25	Data 6 Return	Reference
8	Data 7	To Printer	26	Data 7 Return	Reference
9	Data 8	To Printer	27	Data 8 Return	Reference
10	ACK	To Host	28	ACK Return	Reference
11	Busy	To Host	29	Busy Return	Reference
12	Ptr Error	To Host	30	PE Return	Reference
13	Select	To Host	31	INIT	From Host
14	AutoFD ₁	To Host	32	Fault	To Host
15	Not Used		33	Not Used	
16	Logic Gnd		34	Not Used	
17	FG	Frame Gnd	35	Not Used	
18	+5V (z=24k ohm)	To Host	36	SelectIn ₁	From Host

1 Signals required for ieee 1284 mode.

UNIVERSAL SERIAL BUS (USB)

The Universal Serial Bus (USB) interface is a Plug-In Interface Module that can be installed by the user. It requires a driver (shipped with each printer that has the interface installed) that must be loaded onto the PC and configured to support USB peripherals using Windows 2000 or above. Details for loading the USB driver are contained in the USB Interface Manual that is shipped with each printer with a USB Optional interface installed. Up to 127 devices may be connected to a USB port using powered hubs.

ATTENTION: This Interface Type Is Not Compatible With Windows 98 Or Windows Me.

SPECIFICATIONS	
Printer Connector	USB Type B Plug
Cable	10 feet (3 m) maximum
Host	Windows 2000 or above with USB Port
Power Supply	BUS Power through cable
Power Consumption	+5 V at 80 ma

LOCAL AREA NETWORK (LAN) ETHERNET

A Local Area Network (LAN) interface is an optional Plug-In Interface Module that can be installed by the user. It requires a driver shipped with each printer that has the interface installed. The driver that must be loaded onto the host computer and configured to run one of the supported network protocols using a 10Base-T or 100Base-TX LAN connection. Details for loading the LAN driver are contained in the LAN Interface Manual that is shipped with each printer with a LAN Optional interface installed.

SPECIFICATIONS	
Connector	RJ-45 Receptacle
Cable	10/100BaseT Category 5
Cable Length	100 meters or less
Power Supply	Powered from printer
Protocol	Status3 return Protocol for Driver (cyclic response mode) Protocol for Driver (ENQ response mode) Status5 return
IP Address	0.0.0.0 to 255.255.255.255
Subnet Mask	0.0.0.0 to 255.255.255.255
Gateway Address	0.0.0.0 to 255.255.255.255

DIPSWITCH SETTINGS	
SWITCH	SETTING
1	Reserved (setup prohibited).
2	LAN board EEPROM initialization (configuration).
3	Print configuration details on a label.
4	Print a self-diagnosis of the board onto a label.

SOFTWARE SPECIFICATIONS	
Corresponding Protocol	TCP/IP
Network Layer	ARP, RARP, IP, ICMP
Session Layer	TCP, UDP
Application Layer	LPD, FTP, TELNET, BOOTP, DHCP
<i>NOTE: Print data can be sent by LPR and FTP of TCP/IP and dedicated socket protocol. Printer status is obtainable by dedicated socket protocol.</i>	
<i>NOTE: In the TCP/IP protocol environment, LPD and FTP are provided for printing; TELNET for variable setup; ARP, RARP, and BOOTP/DHCP for address setup.</i>	
<i>LPD protocol complies with RFC1179 and handles the list of logical printer name as queue name such as lp, sjis, euc. In addition, a banner page can be printed by a proper setup.</i>	
<i>When sending the job by LPR, the transmission order of data file/control file within the job will not affect print operation. In addition, if the banner page is specified, it will be added to each data file. Job deletion by LPR is not available.</i>	
<i>FTP protocol complies with RFC959 and handles the list of logical printer name as a transfer directory. File transfer to this directory executes print operation. It is possible to specify ASCII(A), Binary(I) and TENEX(L8) as transfer mode - although the mode difference is dependent on the client. A banner page may be printed with a proper setup.</i>	
<i>TELNET Complies with RFC854. This operation consists of interactive menu form and enables change and reference of internal setup, and to display status. To change the setup, enter "root" user and password at the time of login. Default of root password is set as null (linefeed only).</i>	

802.11B WIRELESS

The wireless print server provides easy printer interface with 802.11b Wi-Fi compliant networks free of wired connections. Each printer is shipped with an integrated driver and interface installed. The driver must be loaded onto the host computer and configured to run one of the supported protocols.

SPECIFICATIONS	
Variable Data Rates	11, 5.5, 2 and 1 Mbps
Frequency Band	2.4 GHz ISM Band
Wired Equivalent Privacy	128 bit, 64 bit (compatible with 40bit), none
Sensitivity	(typ, AAWGN, 8E-2 PER): -91dBm at 1Mbps, -88dBm at 2 Mmps, -87dBm at 5.5Mbps, -84dBm at 11Mbps.
Range	100m indoors, 300m outdoors
Protocols	TCP/IP, IPX/SPX, Direct Mode IPX/IP, DLC/LLC, NetBEUI, NetBIOS/IP
Protocol	Status3 return Protocol for Driver (cyclic response mode) Protocol for Driver (ENQ response mode) Status5 return
IP Address	0.0.0.0 to 255.255.255.255
Subnet Mask	0.0.0.0 to 255.255.255.255
Gateway Address	0.0.0.0 to 255.255.255.255
Communication Mode	802.11 Ad hoc, Ad hoc, Infrastructure
SSID	Optional alphanumeric character string (up to 32 characters)
Channels	01 to 04

DIPSWITCH SETTINGS

The dipswitches serve to initialize the configuration saved on the Wireless-LAN board, print the configuration, and make a self-diagnosis. To communicate with the host, set the communication mode by through switches 5 and 6, then set the remaining switches to the OFF position.

Print of configuration and self-diagnosis are operable only on the screen after turning on the printer. Ensure all switches are in the OFF position when operating the printer.

SWITCH	SETTING		
1	Reserved (setup prohibited).		
2	LAN board EEPROM initialization (configuration).		
3	Print configuration details on a label.		
4	Print a self-diagnosis of the board onto a label.		
5 & 6	5	6	
	ON	ON	Reserved.
	ON	OFF	Ad hoc
	OFF	ON	Infrastructure
	OFF	OFF	802.11 Ad hoc

NOTE: The communication mode may be set within the printer's Interface Mode. Go to [Communication] of the Interface Mode to enable setup by either the dipswitches or through the Interface Mode.

LED INDICATOR STATUS

INDICATOR 1	INDICATOR 2	INDICATOR 3	DESCRIPTION
ON	OFF	OFF	Weak Signal (1-50%)
ON	ON	OFF	Moderate Signal (50-75%)
ON	ON	ON	Strong Signal (75-100%)
OFF	OFF	ON	802.11 Ad hoc
OFF	ON	OFF	Ad hoc

SOFTWARE SPECIFICATIONS

Corresponding Protocol	TCP/IP
Network Layer	ARP, RARP, IP, ICMP
Session Layer	TCP, UDP
Application Layer	LPD, FTP, TELNET, BOOTP, DHCP

NOTE: Print data can be sent by LPR and FTP of TCP/IP and dedicated socket protocol. Printer status is obtainable by dedicated socket protocol.

NOTE: In the TCP/IP protocol environment, LPD and FTP are provided for printing; TELNET for variable setup; ARP, RARP, and BOOTP/DHCP for address setup.

LPD protocol complies with RFC1179 and handles the list of logical printer name as queue name such as lp, sjis, euc. In addition, a banner page can be printed by a proper setup.

When sending the job by LPR, the transmission order of data file/control file within the job will not affect print operation. In addition, if the banner page is specified, it will be added to each data file. Job deletion by LPR is not available.

FTP protocol complies with RFC959 and handles the list of logical printer name as a transfer directory. File transfer to this directory executes print operation. It is possible to specify ASCII(A), Binary(I) and TENEX(L8) as transfer mode - although the mode difference is dependent on the client. A banner page may be printed with a proper setup.

TELNET Complies with RFC854. This operation consists of interactive menu form and enables change and reference of internal setup, and to display status. To change the setup, enter "root" user and password at the time of login. Default of root password is set as null (linefeed only).

1) Printing by socket

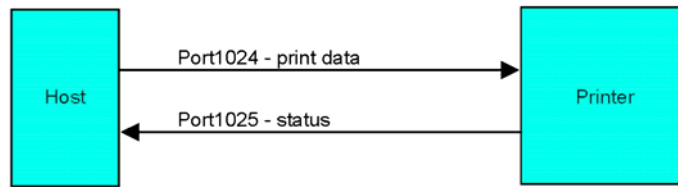

2) Printing by LPR and FTP

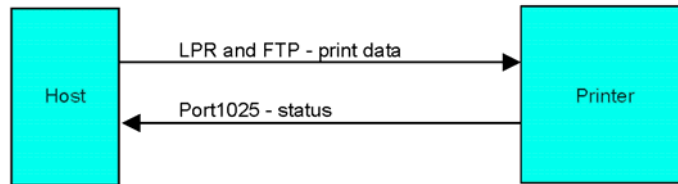

Figure 3-10, Socket Connection Diagram

ALL INTERFACES

RECEIVE BUFFER

The data stream is received from the host to the printer one job at a time. This allows the software program to maintain control of the job print queue so that it can move a high priority job in front of ones of lesser importance. A multiple job buffer allows the printer to continuously receive print jobs while compiling and printing other jobs at the same time. It acts much like a Print buffer to maximize the performance of the host and the printer.

The printer receives and prints one job at a time. If a print job exceeds the buffer size, transmission will be rejected by the printer. Flow control protocols to throttle transmission are not used. Error conditions that occur during the Print Data transmission will cause the printer to return a NAK.

ACK/NAK PROTOCOL

Bi-Directional ACK/NAK protocol is used for error control. In a normal transmission sequence when the transmission is received, the printer will return an ACK (06H) signifying that it was received without a transmission error. After the transmission command structure has been analyzed, a status byte is returned to the host. This status byte informs the host of the validity of the command structure.

If the command structure is error free, the printer proceeds with the print operation. When the print operation is completed, a Printer Status message is returned to the host. If an error was detected during the initial transmission sequence, a NAK (15H) will be returned signalling to the host that the received transmission contained errors and must be resent. If the returned Status byte indicates a command structure error, the error must then be corrected before the print data is resent to the printer.

A valid transmission to the printer must be bounded by an STX/ETX pair, with the STX (02H) signifying the start of the Print Data and ending with an ETX (03H) signifying the end.

STATUS5 RETURN

This communication protocol is designed for the purpose of monitoring and controlling print data status in the host and featuring various functions.

INTERFACE SIGNALS		
PIN	DIRECTION	SIGNAL DEFINITION
1	Reference	FG (Frame Ground)
2	To Host	TD (Transmit Data) - Data from the printer to the host computer.
3	To Printer	RD (Receive Data) - Data to the printer from the host computer.
7	Reference	SG (Signal Ground)

CABLE REQUIREMENTS					
Depending on the host used, it may need to loop CS and RS (maintaining at high level) on the hose side. For additional information, refer to the host computer documentation.					
DB9	DB25	HOST	DIRECTION	DB25	PRINTER
1	1	FG (Frame Ground)	Bi-Directional	1	FG (Frame Ground)
2	3	RD (Receive Data)	To Host	2	TD (Transmit Data)
3	2	TD (Transmit Data)	To Printer	3	RD (Receive Data)
5	7	SG (Signal Ground)	Bi-Directional	7	SG (Signal Ground)

RECEIVE BUFFER CONTROL	
Causes For Receive Buffer Near Full	Receive buffer near full occurs when the remaining free space of the buffer drops to 0.95MB of 2.95MB capacity or when the remaining free space is available for storing 50 of 500 items in the history buffer.
Release Of Receive Buffer Near Full	Receive buffer near full can be released when the remaining free space rises to 1.95MB or when the remaining free space is available for storing 200 items in the history buffer.

STATUS5 TIMING CHARTS

NORMAL PROCESS

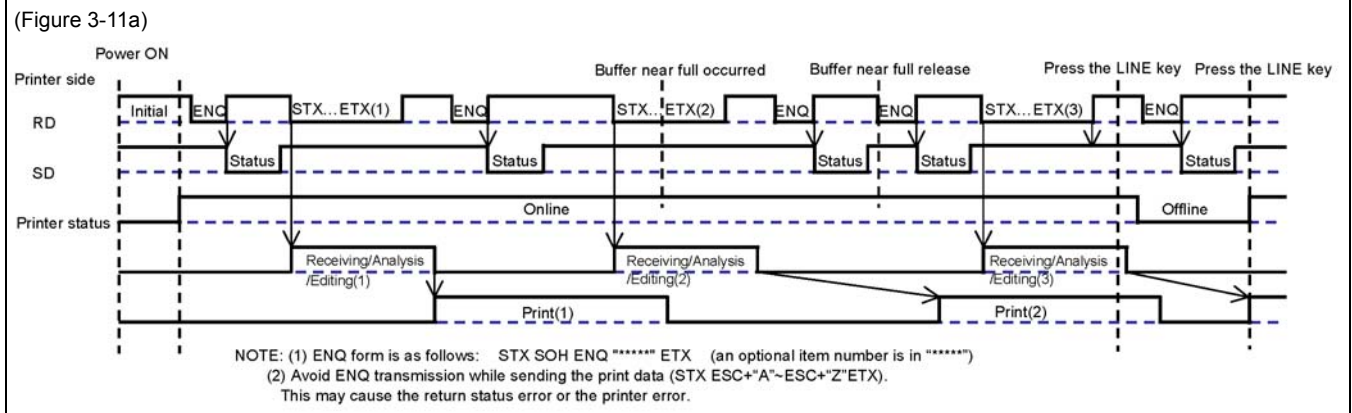

CANCEL PROCESS

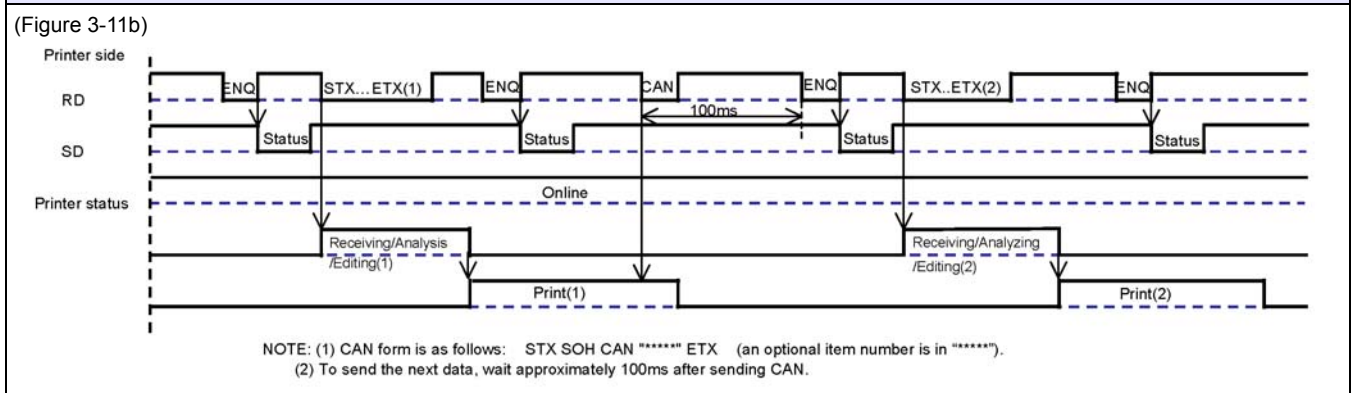

ERROR PROCESS

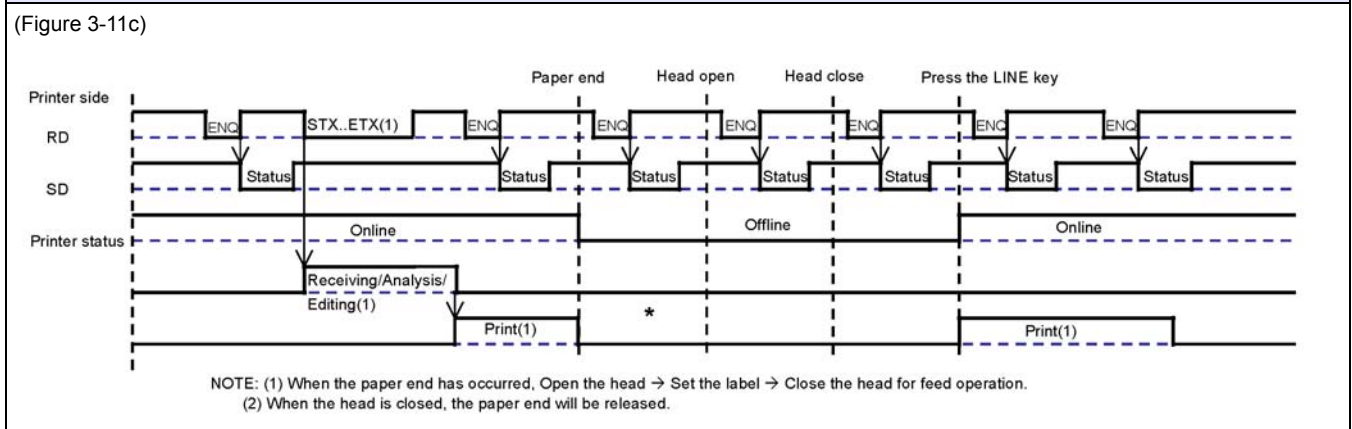

STATUS5 TIMING CHARTS

PRINT PROCESS

(Figure 3-11d)

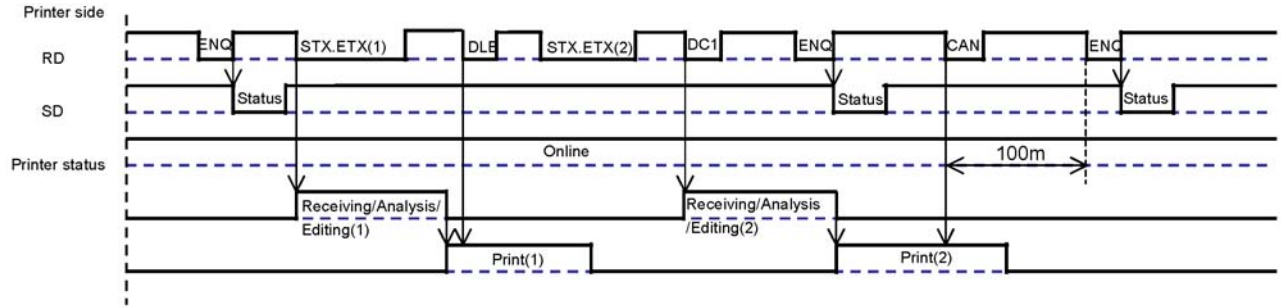

NOTE: (1) DLE form: STX SOH DLE ETX

COMMAND PROCESS

(Figure 3-11e)

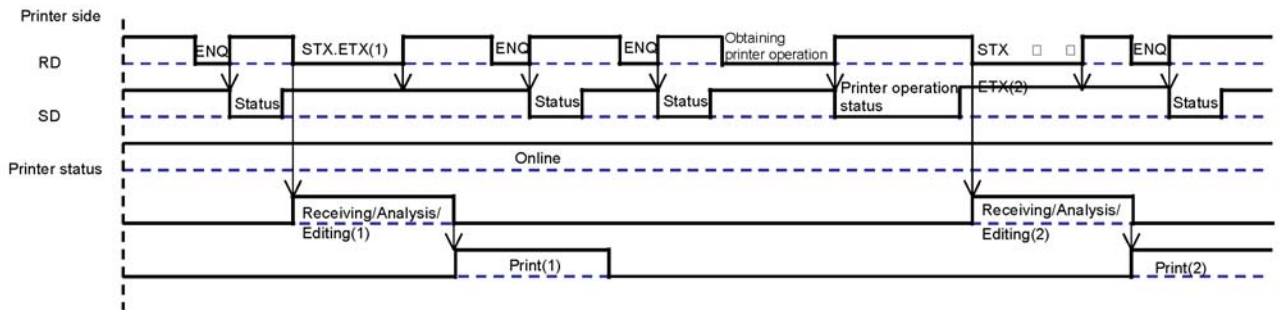

NOTE: Avoid executing the command to obtain status (e.g. printer operation status) while printing.

BCC ERROR PROCESS

(Figure 3-11f)

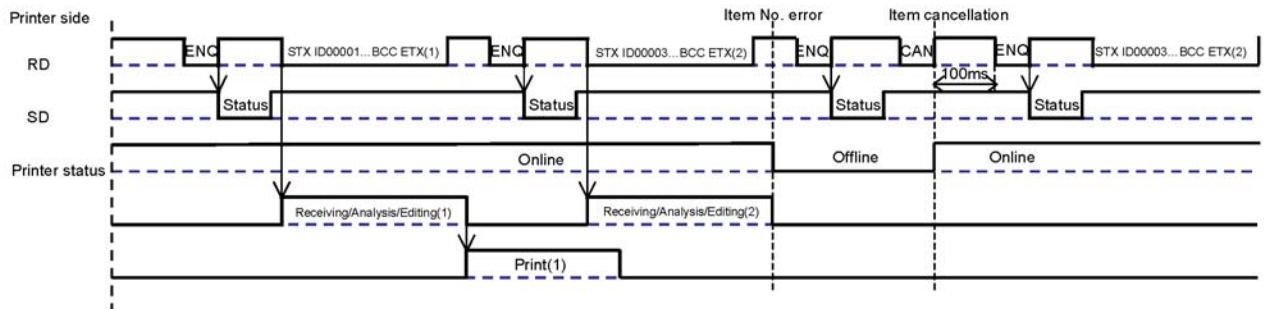

NOTE: Avoid executing the command to obtain the status (e.g. printer operation status) while printing.

EXTERNAL SIGNAL

The external signal interface is designed to connect the printer to an applicator. Proceed to the printer's Advanced Mode for various setup activities related to the external signal.

There are two connector types available for the external signal interface, one with a 14-pin connector and the other with a 25-pin connector.

SPECIFICATIONS	
Signal Level	High: +2.4 to +5.0V, Low: +0.0 to +0.4V
Issuing/Reissuing EXT signal	Enable/Disable in the Advanced Mode.
Switching EXT signal	Switching jumper connector to enable +24V output by 24V and 27V power supplies. When using 24V power supply: Short IN 24V side by jumper connector When using 27V power supply: Short IN 27V side by jumper connector.
Signal Types	<p>Type I Print end signal (PREND) is "low" before printing labels, "high" after completion of print, and "low" 20 milliseconds later.</p> <p>Type II Print end signal (PREND) is "high" before printing labels, "low" after completion of print, and "high" 20 milliseconds later.</p> <p>Type III Print end signal (PREND) is "low" before printing labels, "high" from start to end of print, and "low" upon completion of print.</p> <p>Type IV Print end signal (PREND) is "high" before printing labels, "low" from start to end of print, and "high" upon completion of print.</p>

14-PIN CONNECTOR ASSIGNMENTS				
PIN	SIGNAL NAME	DIRECTION	LEVEL	MAX CURRENT
1	Paper End	Output	Low	5V, 400mA
2	Ground	--	--	--
3	Ribbon End	Output	High	5V, 400mA
4	Machine Error	Output	Low	5V, 400mA
5	Print Start (PRIN)	Input	Low	High: high impedance, Low: -15mA or more, 0V
6	Print End (PREND)	Output	Low	5V, 400mA
7	Reprint (PRIN2)	Input	Low	High: high impedance, Low: -15mA or more, 0V
8	EXT5V_IN	Input		5V
9	Online	Output	Low	5V, 400mA
10	Ribbon Near End	Output	Low	5V, 400mA
11	--	--	--	--
12	+24V	--	--	--
13	+5V	--	--	--
14	FG	--	--	--

Choose from Type I to Type IV for PREND (the output signal for Pin 6).

Unit 3: Installation

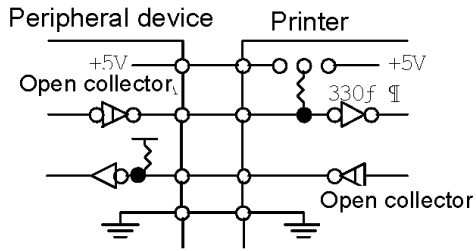

Figure 3-12, Input/Output Circuit Diagram

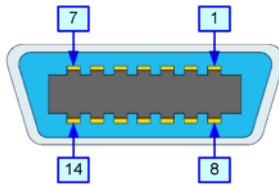
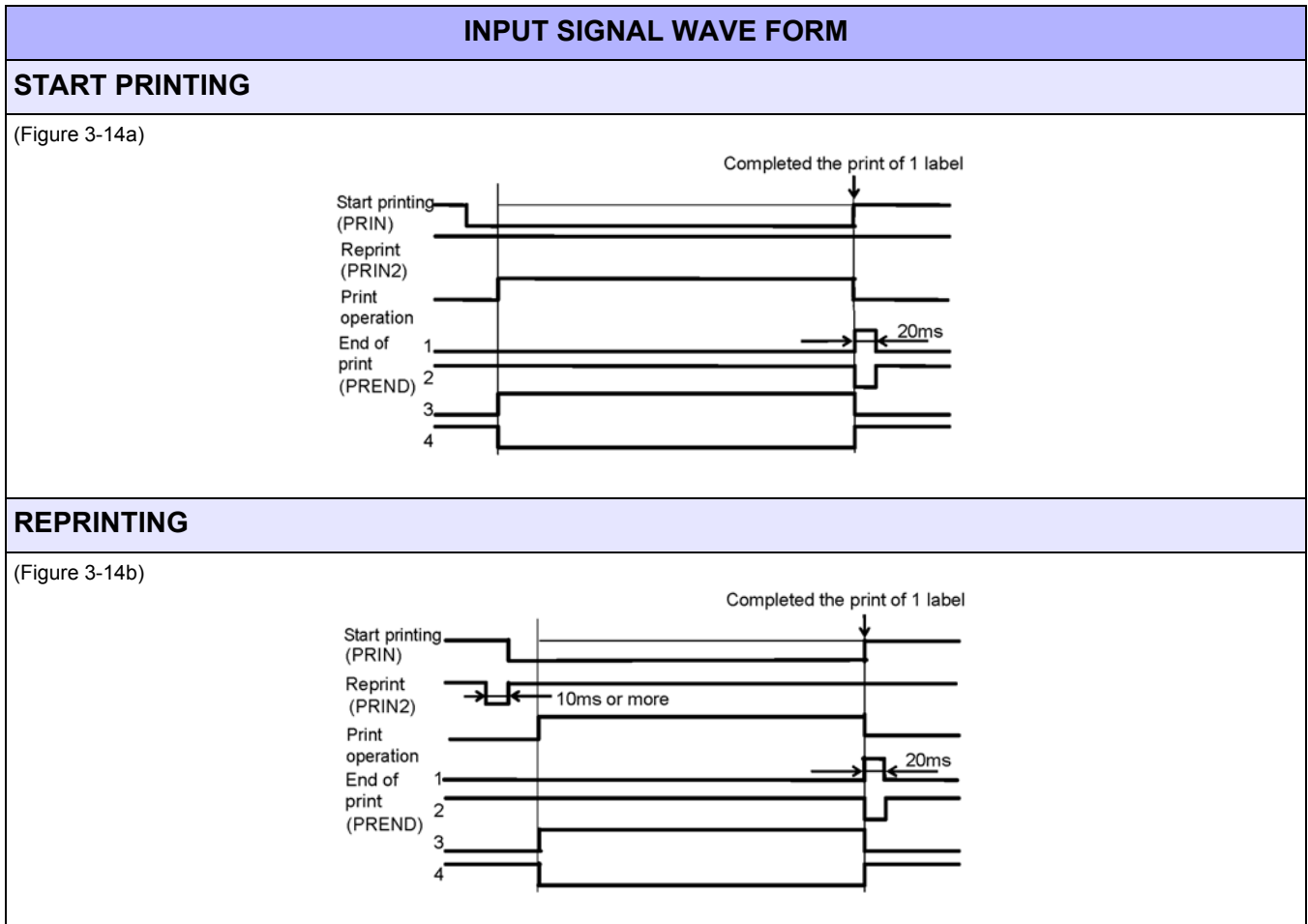

Figure 3-13, 14-Pin Connector Assignments



OUTPUT SIGNAL WAVE FORM

BASIC OPERATION

(Figure 3-15a)

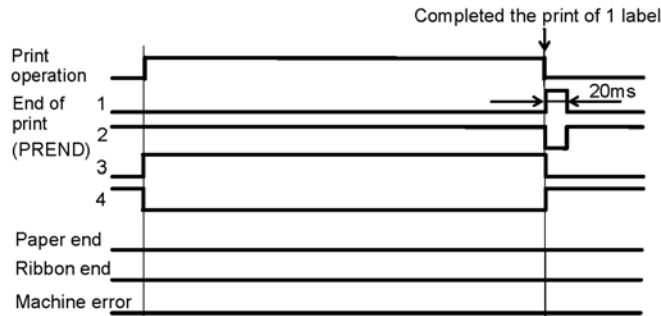

PAPER END

(Figure 3-15b)

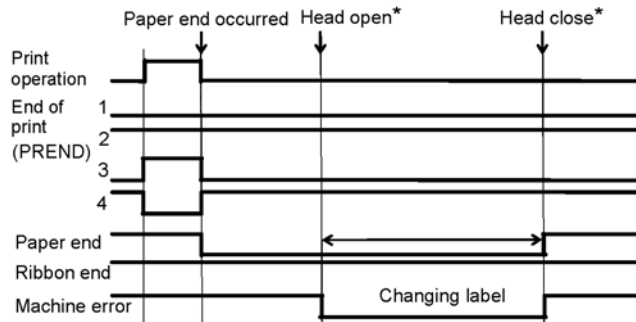

RIBBON END

(Figure 3-15c)

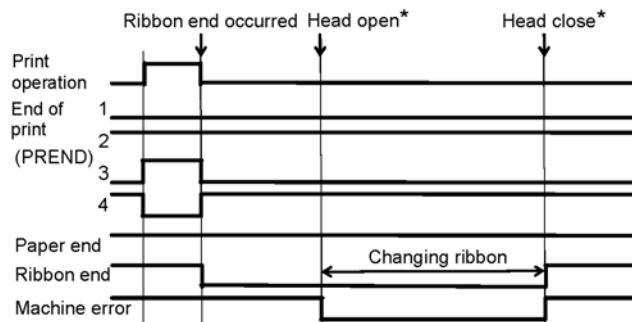

MACHINE ERROR

(Figure 3-15d)

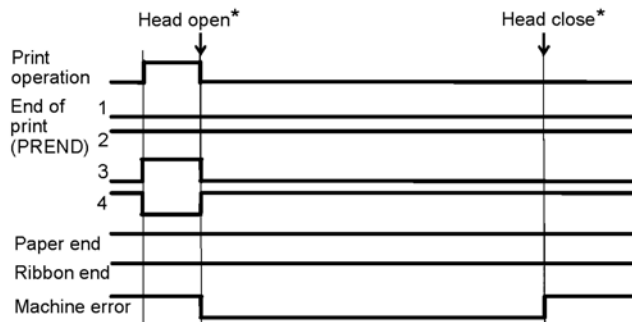

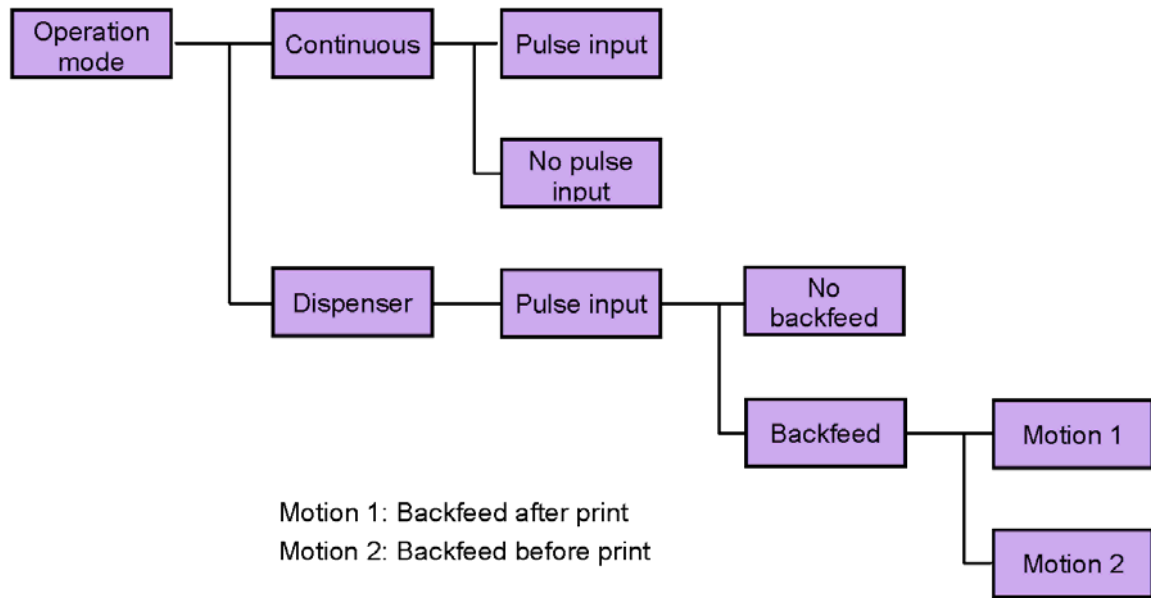

Figure 3-16, Operation Mode Flow Chart

ACCESSORIES INSTALLATION

This unit covers all of printer accessory installation procedures.

INTERFACE INSTALLATION

The diagram below displays the physical installation of interface hardware. The interface type chosen determines the applicable slot in the printer for installation.

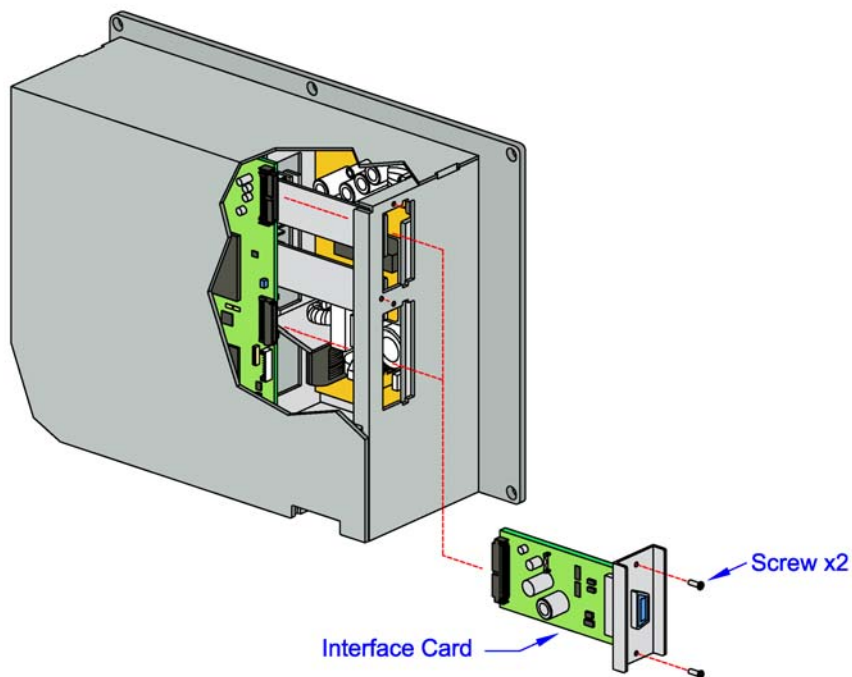

Figure 3-17, Interface Installation

4

PRINTER CONFIGURATION

- **Printer Configuration**
- **Configuration Modes**
- **Menu Definition Tables**

PRINTER CONFIGURATION

This unit provides in-depth instruction on printer configuration for operation and for some troubleshooting.

The printer may be configured via the buttons and/or potentiometers located on the printer's operator panel. All of the printer's buttons, switches, and potentiometers are used either singularly, or in conjunction, to perform configuration activities.

Refer to the Control Features chapter of the Introduction unit for identification of specific interface features.

ADVANCED MODE

The Advanced Mode is provided to make basic printer operational adjustments. Typically, once these adjustments or settings have been made, they will not require additional address unless a new job is downloaded. Use the keys of the printer's operator panel to select and enter the required options.

Refer to the Menu Definition Tables in the following chapter to provide an explanation of each menu screen.

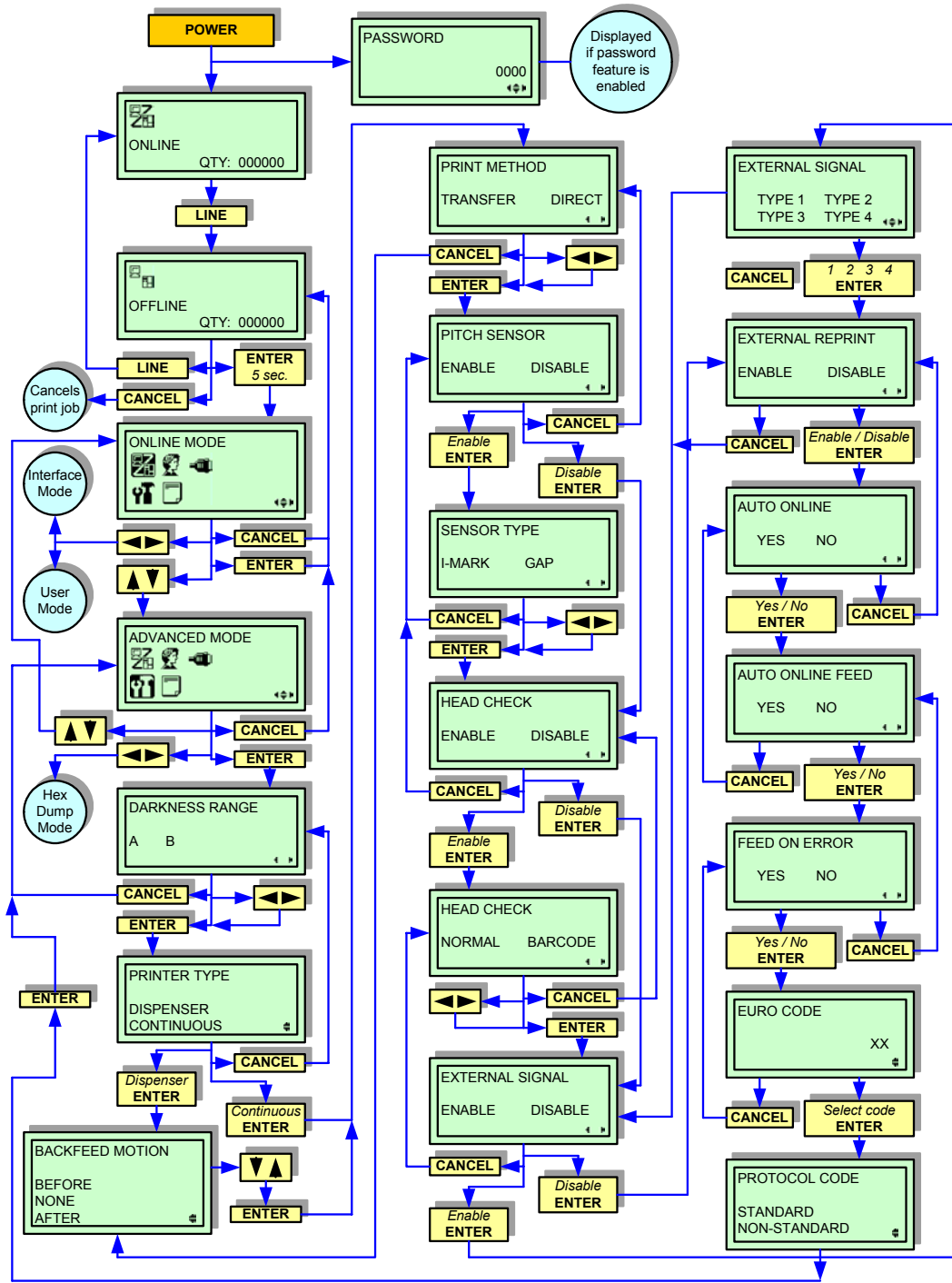

Figure 4-2, Advanced Mode

PARALLEL INTERFACE SETUP MODE

This chapter provides the programming sequences required for IEEE1284 interface setup. Use the keys of the printer's operator panel and enter the required options.

Refer to the Menu Definition Tables in the following chapter to provide an explanation of each menu screen.

ATTENTION: Do not perform the following programming sequence if this is not the interface type to be used. Instead, refer to the appropriate interface programming flow chart.

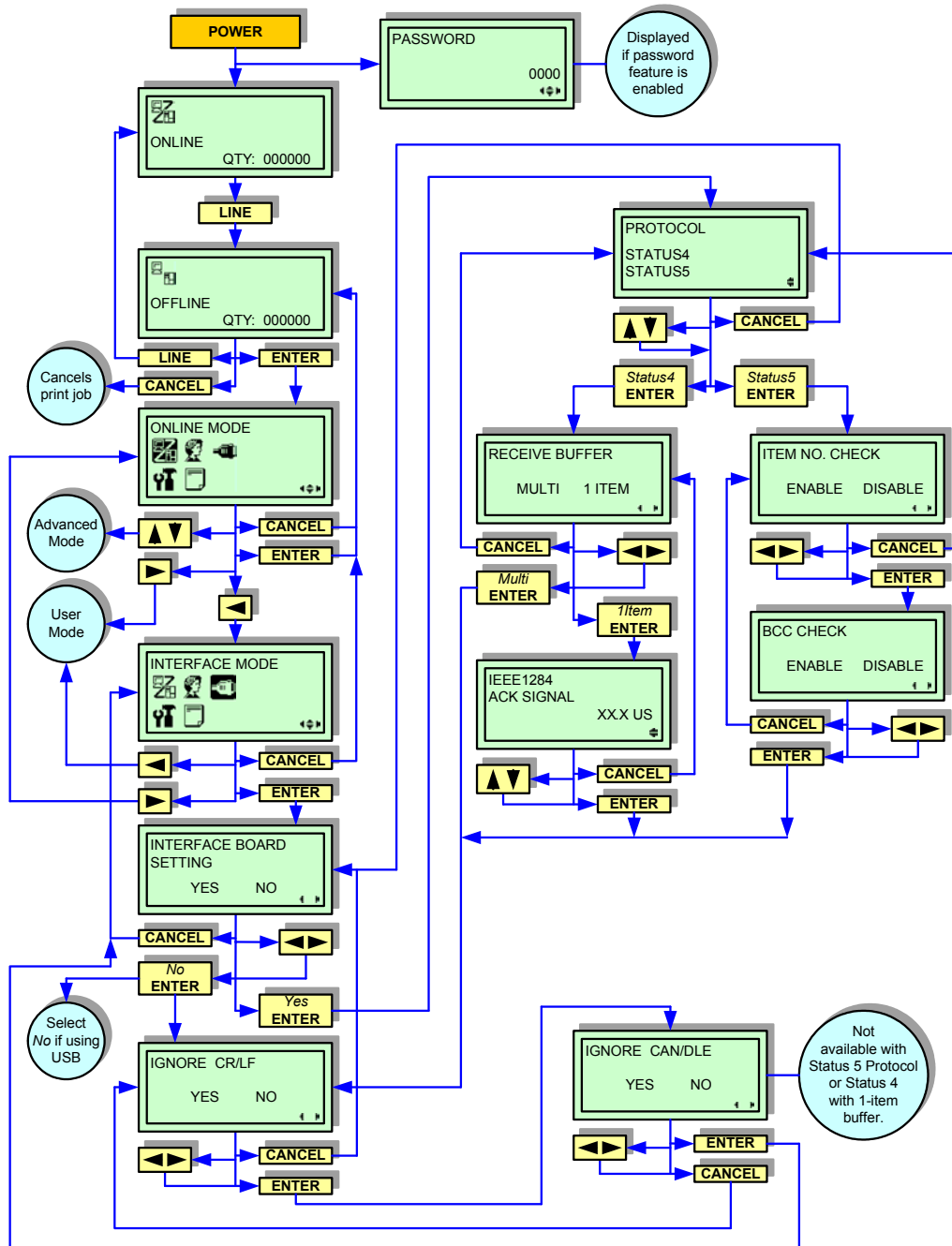

Figure 4-3, Parallel Interface Setup Mode

SERIAL INTERFACE SETUP MODE

This chapter provides the programming sequences required for RS232C, RS422, or RS485 interface setup. Use the key of the printer's operator panel to select and enter the required options.

Refer to the Menu Definition Tables in the following chapter to provide an explanation of each menu screen.

ATTENTION: Do not perform the following programming sequence if this is not the interface type to be used. Instead, refer to the appropriate interface programming flow chart.

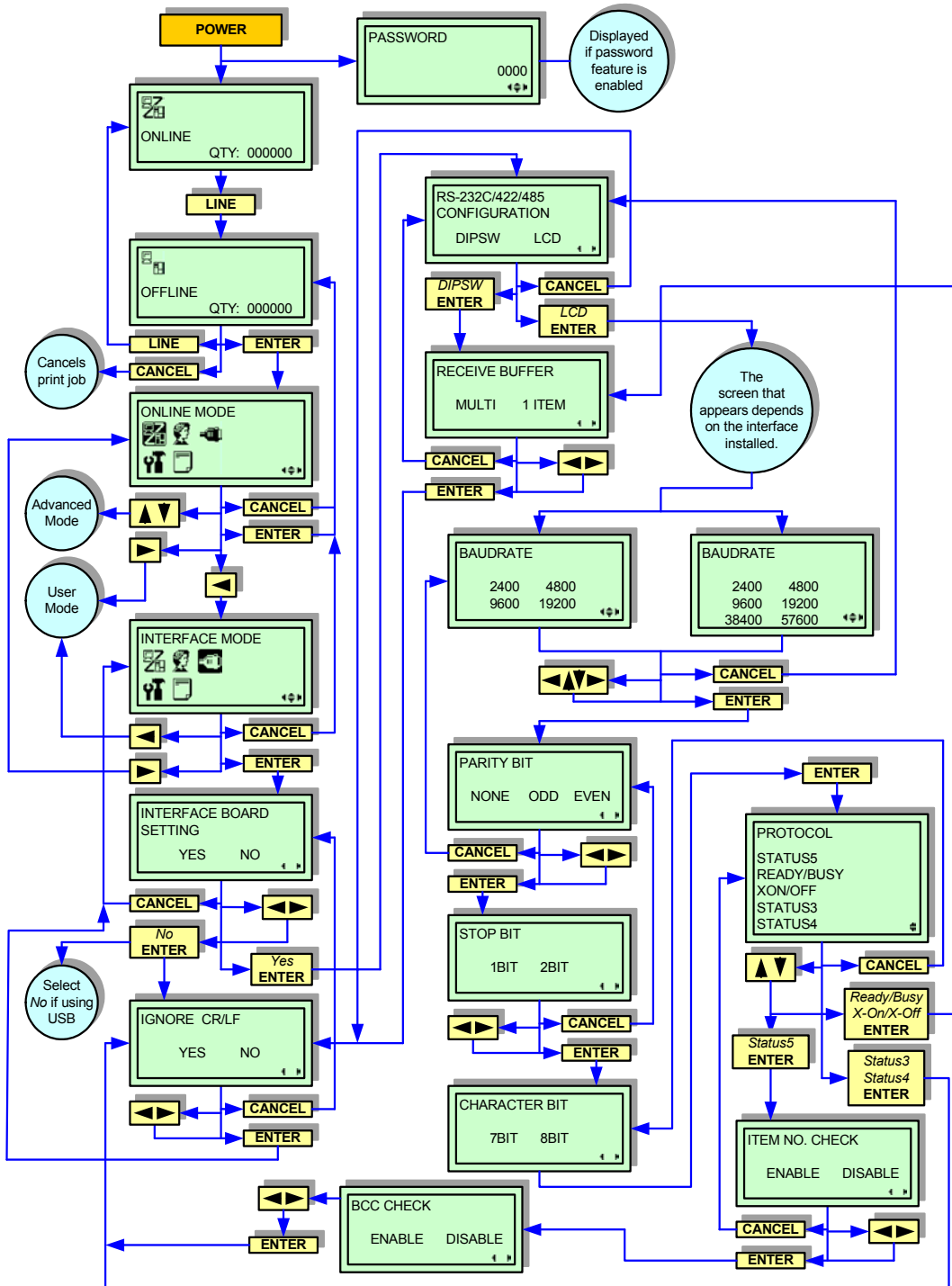

Figure 4-4, Serial Interface Setup Mode

LOCAL AREA NETWORK (LAN) INTERFACE SETUP MODE

This chapter provides the programming sequences required for LAN, Wireless LAN, and Mini-LAN interface setup. Use the keys of the printer's operator panel to select and enter the required options.

Refer to the Menu Definition Tables in the following chapter to provide an explanation of each menu screen.

ATTENTION: Do not perform the following programming sequence if this is not the interface type to be used. Instead, refer to the appropriate interface programming flow chart.

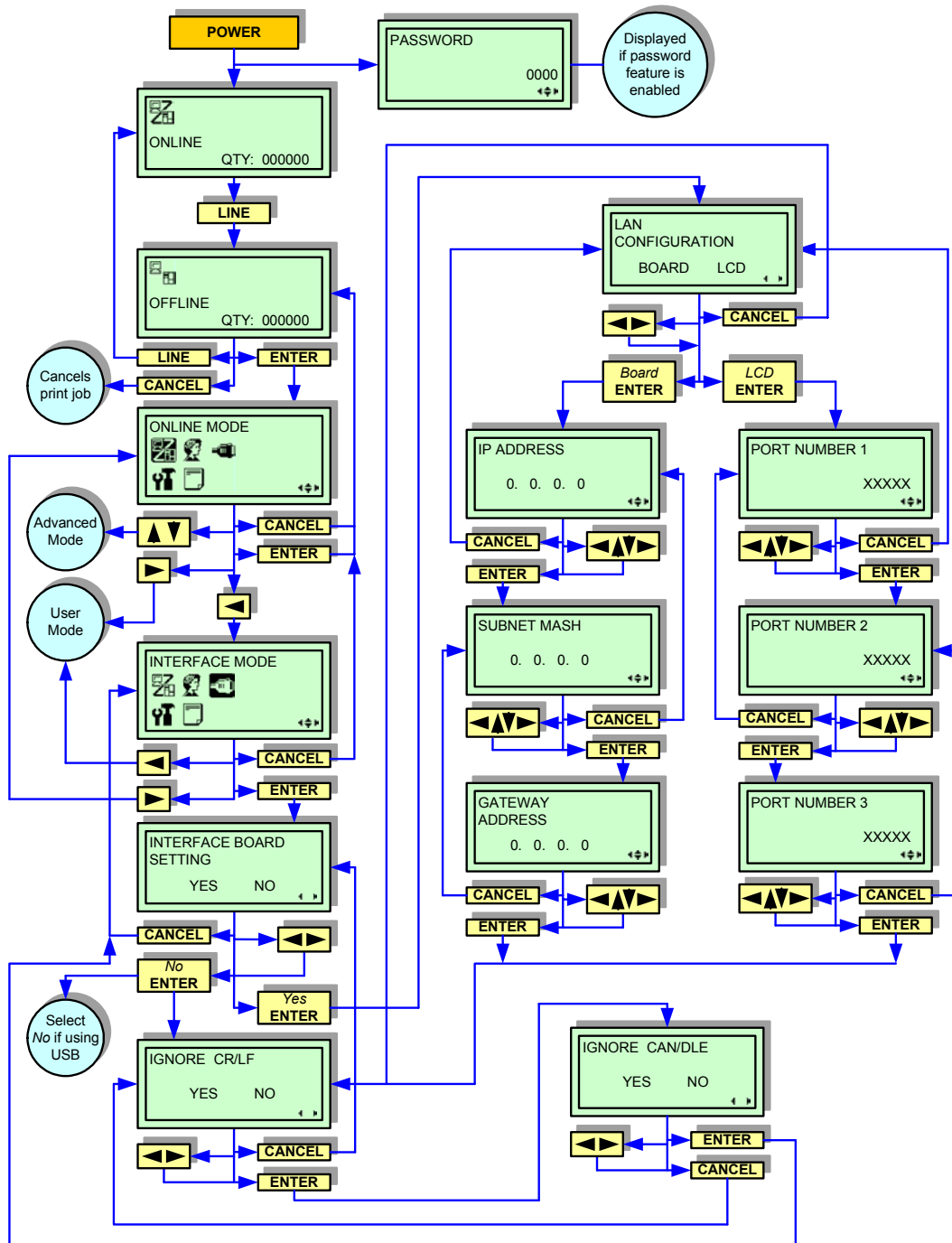

Figure 4-5, LAN Interface Setup Mode

USB INTERFACE SETUP MODE

This chapter provides the programming sequences required for USB interface setup. Use the keys of the printer's operator panel to select and enter the required options.

Refer to the Menu Definition Tables in the following chapter to provide an explanation of each menu screen.

ATTENTION: Do not perform the following programming sequence if this is not the interface type to be used. Instead, refer to the appropriate interface programming flow chart.

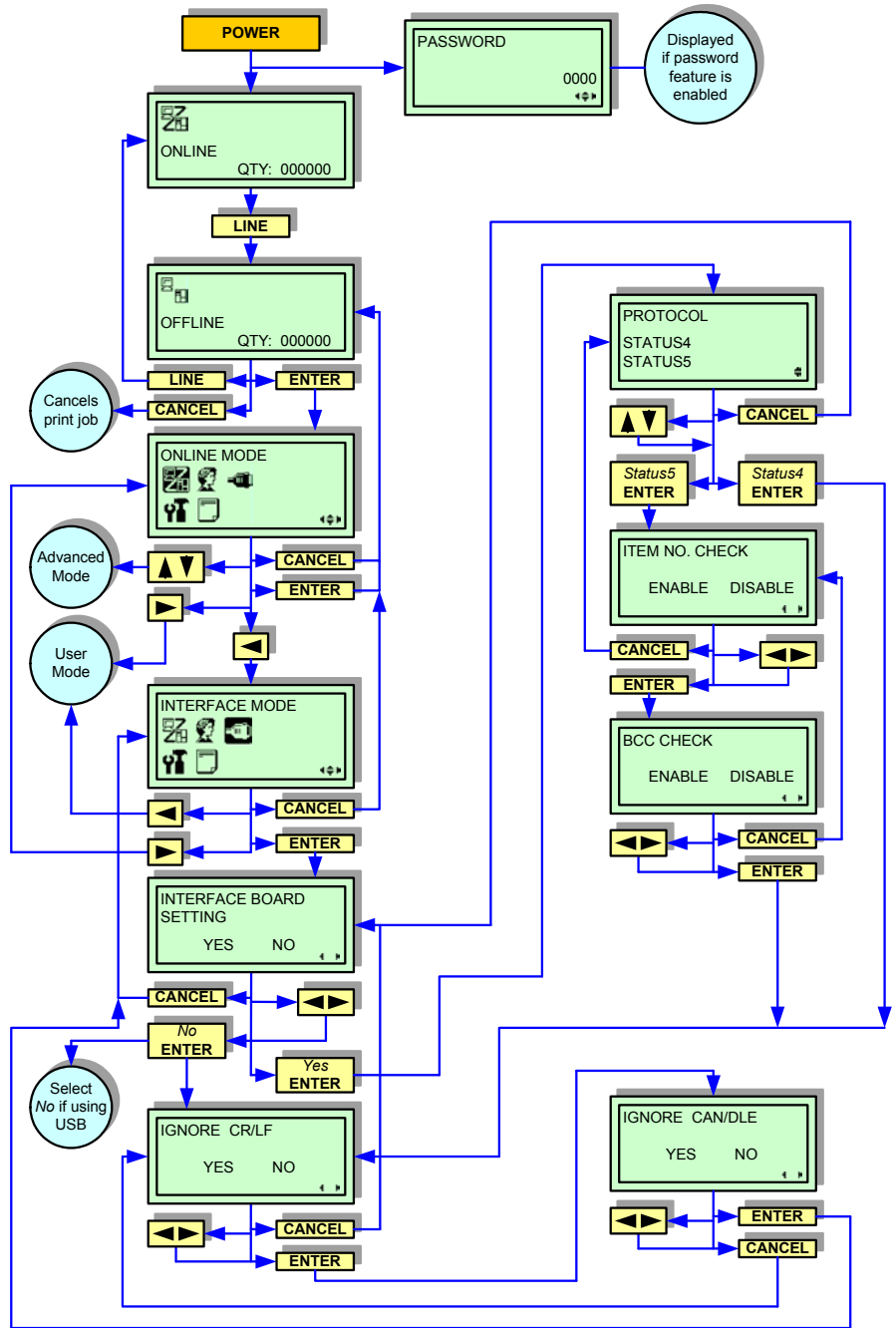

Figure 4-6, USB Interface Setup Mode

SERVICE MODE

Allows the programming of various dimensional settings, sensor thresholds, and language options. Use the keys of the printer's operator panel to select and enter the required options.

Refer to the Menu Definition Tables in the following chapter to provide an explanation of each menu screen.

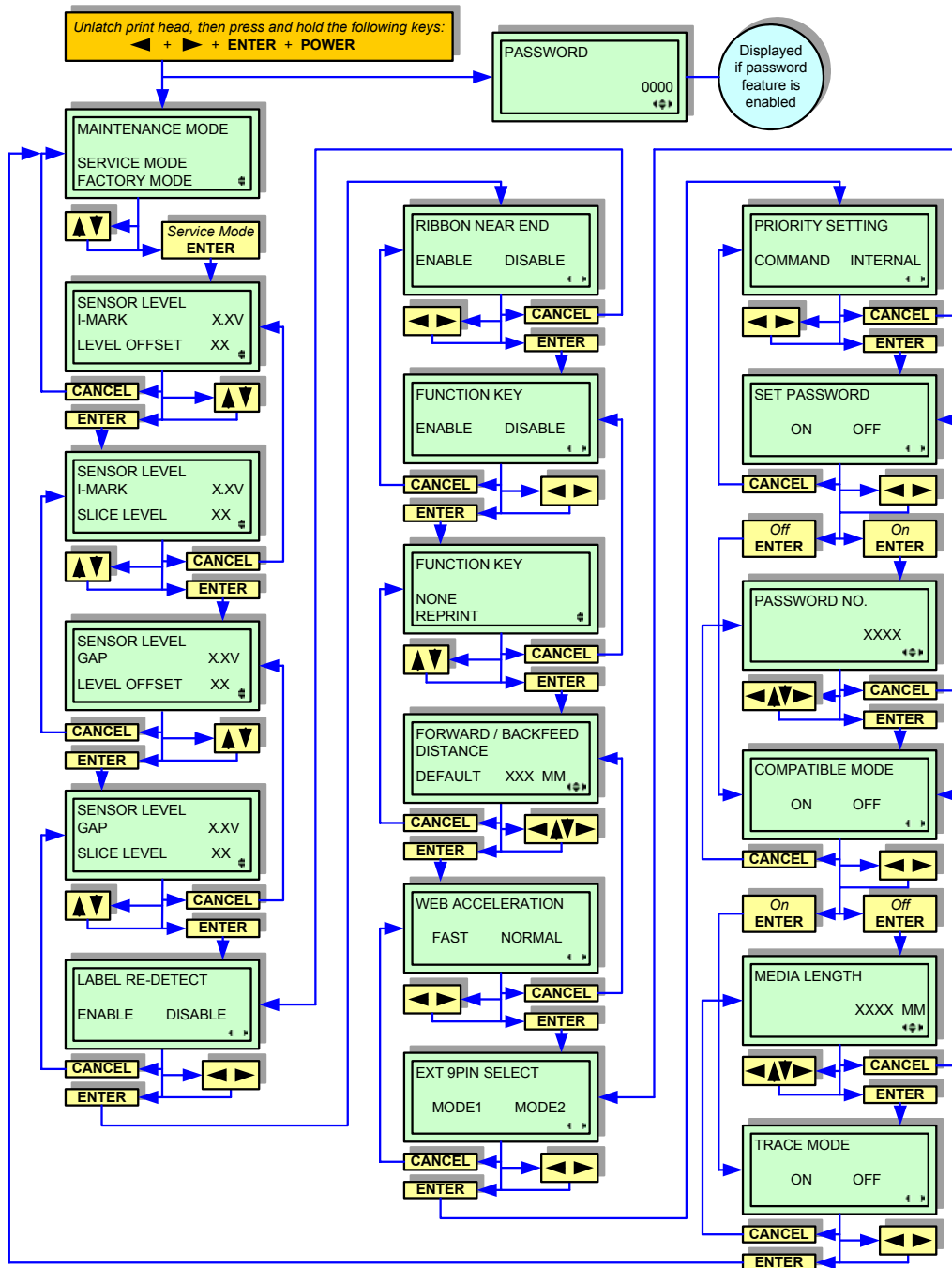

Figure 4-8, Service Mode

FACTORY MODE

The Factory Mode permits counter reset of various printer components. Use the keys of the printer's operator panel to select and reset those features.

Refer to the Menu Definition Tables in the following chapter to provide an explanation of each menu screen.

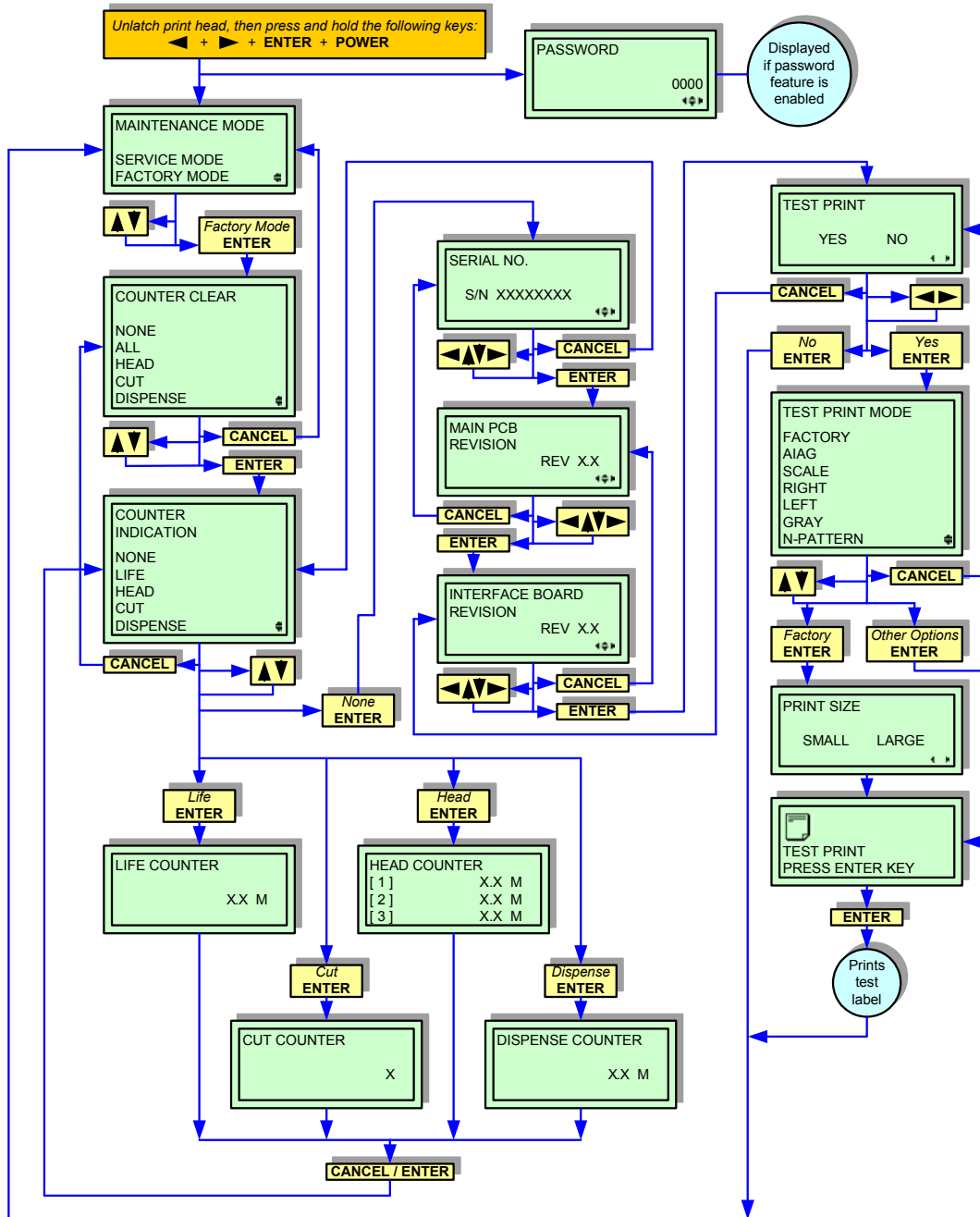

Figure 4-9, Factory Mode

WORK SHIFT MODE

The Work Shift mode allows for specific production information regarding printing activity on a given work shift to be recorded. Use the keys of the printer's operator panel to select and enter the required options.

Refer to the Menu Definition Tables in the following chapter to provide an explanation of each menu screen.

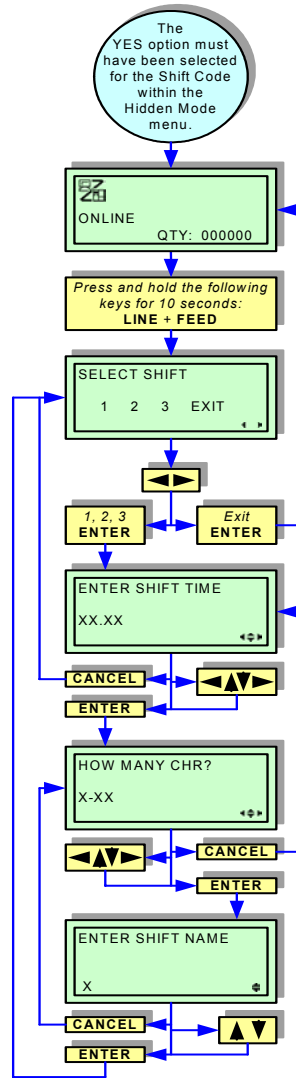

Figure 4-10, Work Shift Mode

HIDDEN MODE

Use the keys of the printer's operator panel to select and enter the required options.

Refer to the Menu Definition Tables in the following chapter to provide an explanation of each menu screen.

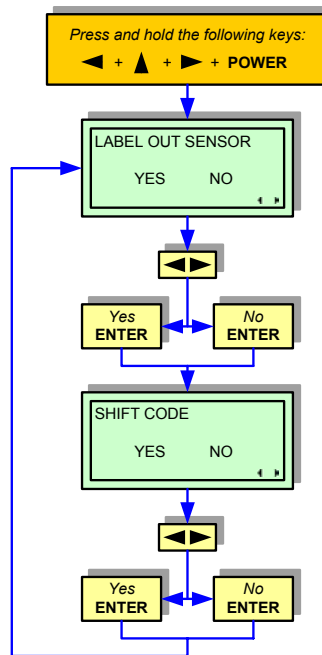

Figure 4-11, Hidden Mode

DOWNLOAD MODE

This download feature allows the operator to downgrade or upgrade Firmware to the printer. When downloading is complete, the LCD screen will return to the original display. If an error occurs, a DOWNLOAD ERROR will display.

Use the keys of the printer's operator panel to select and enter the required options.

Refer to the Menu Definition Tables in the following chapter to provide an explanation of each menu screen.

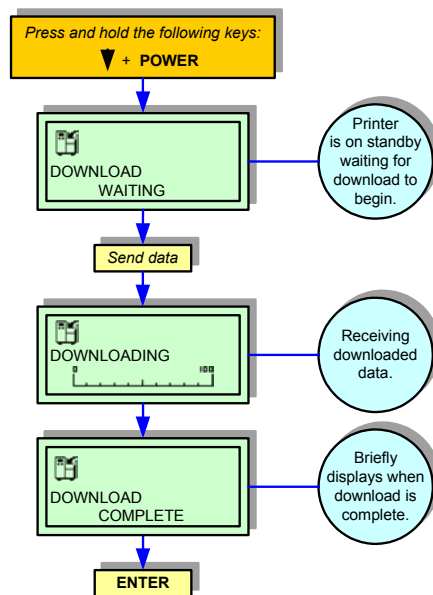

Figure 4-12, Download Mode

BOOT DOWNLOAD MODE

This download mode is used when the Firmware becomes corrupted and the normal download mode is not successful.

Figure 5-13 provides the specific sequence of events required by the operator, the printer, and the printer's software for downloading Firmware to the printer. Use the key of the printer's operator panel to select and enter the required options.

Refer to the Menu Definition Tables in the following chapter to provide an explanation of each menu screen.

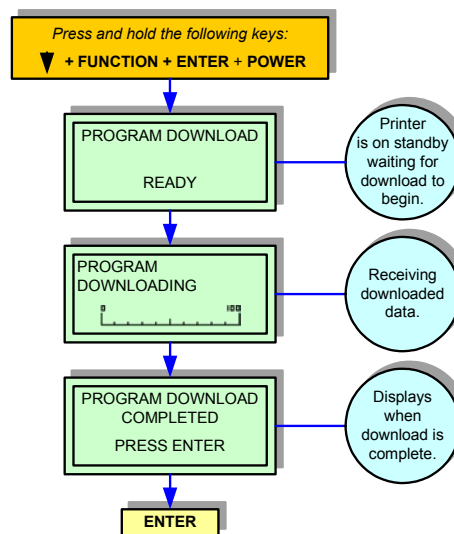

Figure 4-13, Boot Download Mode

PRINT CANCEL MODE

Figure 5-14 provides the specific sequence of events required by the operator, the printer, and the printer's software to cancel a print job once initiated. Use the keys of the printer's operator panel to select and enter the required options.

Refer to the Menu Definition Tables in the following chapter to provide an explanation of each menu screen.

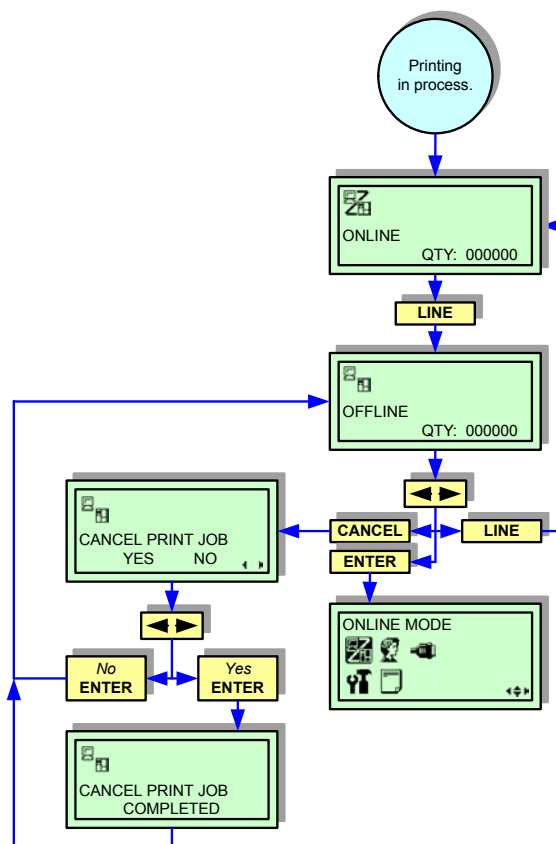

Figure 4-14, Print Cancel Mode

DEFAULT SETTING MODE

Figure 5-15 provides the specific sequence of events required by the operator, the printer, and the printer's software to return the printer to the configuration state as received from the factory. Use the keys on the printer's operator panel to select and enter the required options.

Refer to the Menu Definition Tables in the following chapter to provide an explanation of each menu screen.

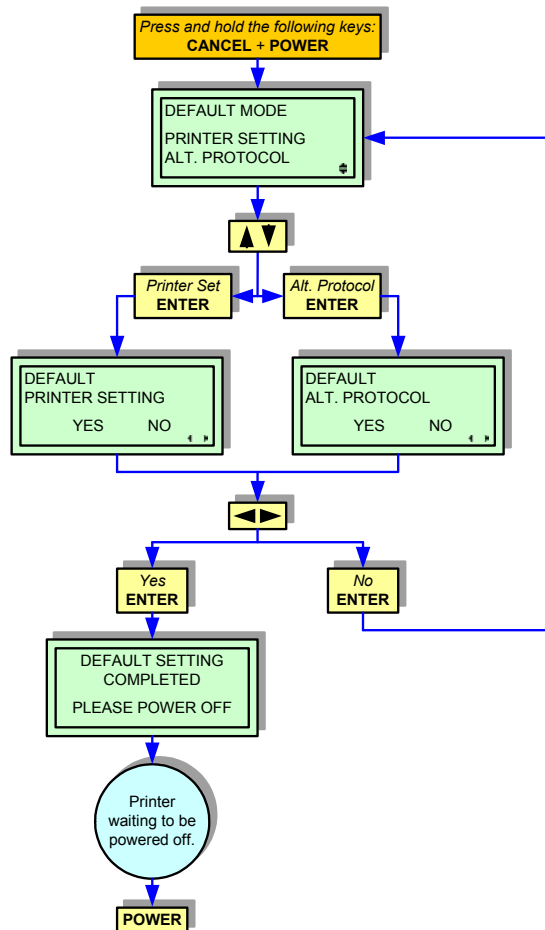

Figure 4-15, Default Setting Mode

TEST PRINT MODE

Figure 5-16 provides the specific sequence of events required by the operator, the printer, and the printer's software for a test label to be printed. Test labels are designed to identify failures in configuration, adjustment problems, and mechanical defects. Use the key on the printer's operator panel to select and enter the required options.

Refer to the Menu Definition Tables in the following chapter to provide an explanation of each menu screen.

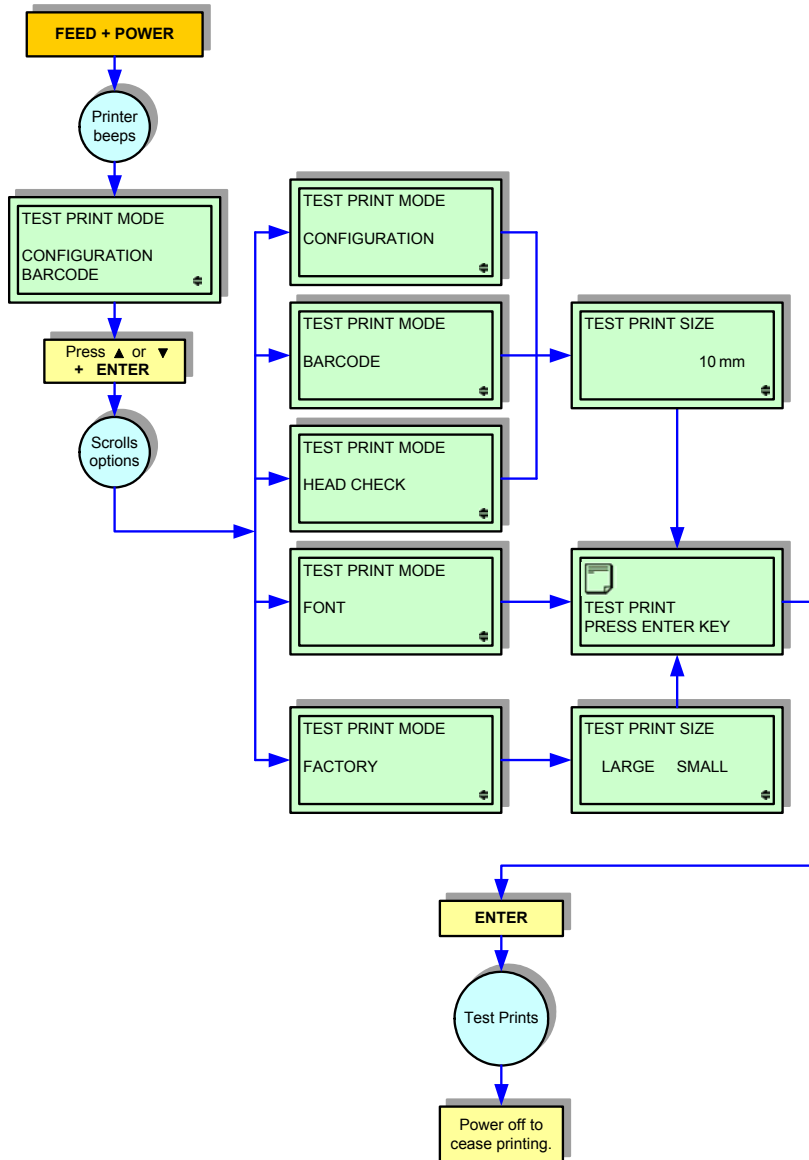

Figure 4-16, Test Print Mode

HEX DUMP MODE

The contents of the print buffer and the data received before it is placed into the print buffer may be examined through the use of the Hex Dump Mode. Each line of the printed data is enumerated in the first column, the second column contains the data in hexadecimal format, and the right column contains the same data in ASCII format.

The options of data to be printed are: receive data, receive buffer, and internal data. However, only one type of data may be printed on a single label. Repeat the dump process to print the other data types as desired.

Use the keys on the printer's operator panel to select and enter the required options.

Refer to the Menu Definition Tables in the following chapter to provide an explanation of each menu screen.

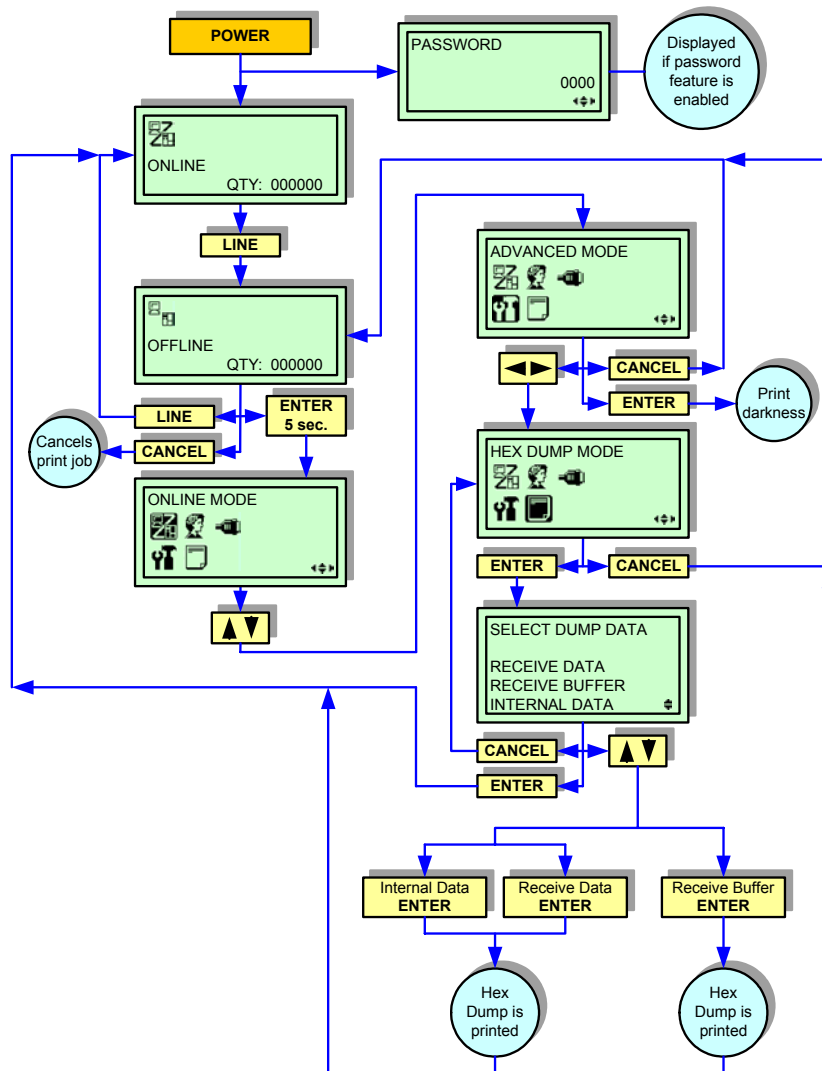
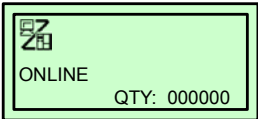
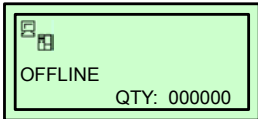
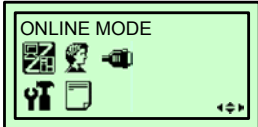
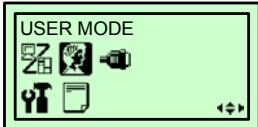

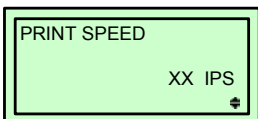
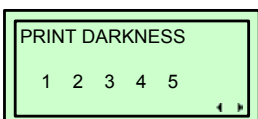
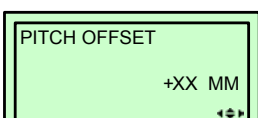
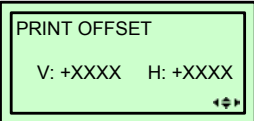
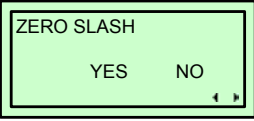
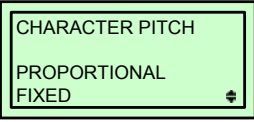
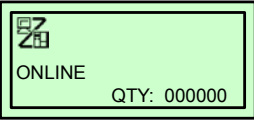
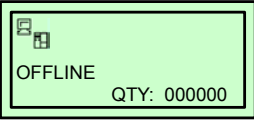
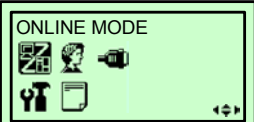
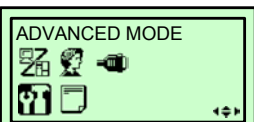



Figure 4-17, Hex Dump Mode

MENU DEFINITION TABLES

USER MODE (TABLE 4-1)	
MENU	DESCRIPTION
	Displays the operational status of the printer. The ONLINE status is displayed on the top line and the label quantity status on the bottom. The message will be changed to OFFLINE whenever the printer is switched offline by pressing the LINE key. When a print job is received, the quantity line will indicate the number of labels to be printed. As the label job prints, the display indicates the number of labels remaining to be printed.
	Displays the operational status of the printer. The OFFLINE status is displayed on the top line and the label quantity status on the bottom. The message will be changed to ONLINE whenever the printer is switched online by pressing the LINE key.
	Is a transitional screen that allows the operator to choose a given direction within the menu map.
	Is the entrance screen of the User Mode. The User Mode allows various print parameters to be set.
	This screen shows the adjusted value for the potentiometers on the Operator Panel. Entry is not required for this screen. The values will change as the potentiometers are adjusted.
	Permits the printer's print speed to be established based on inches per second (IPS).
	Permits the adjustment of the print density. Higher print density equates to darker print images.
	<p>The label pitch is the distance from the leading edge (the edge that comes out of the printer first) of a label and the leading edge of the next label. The position of the label's leading edge can be adjusted relative to the print head in increments of 1mm. Once the position has been set, it can be fine adjusted using the PITCH potentiometer.</p> <p>Positive (+) digit selection on the display moves the leading edge forward and away from the print head while a negative (-) selection moves the label's leading edge incrementally back into the mechanism.</p>

USER MODE (TABLE 4-1)	
MENU	DESCRIPTION
	<p>Print offset refers to the vertical and horizontal shifting of the entire print area relative to the label and the print start position. The movement is incremented by dots in the positive (+) or negative (-) direction. Positive and negative vertical adjustment is toward and away from the print head respectively. Positive and negative horizontal adjustment is to the left or right of the reference point respectively.</p>
	<p>This menu allows for the printer to be configured to print zeros with or without a diagonal slash through them. This will apply to all printer resident font types.</p>
	<p>This setting determines whether each character occupies a designated space (fixed) regardless of the characters width or if the character's space is representative of the character's width (proportional). Proportional is contemporarily preferred. Applies only to printer resident fonts.</p>

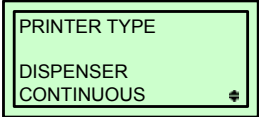
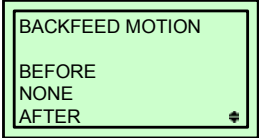
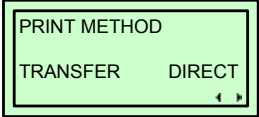
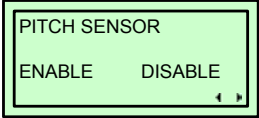
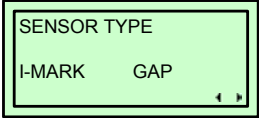
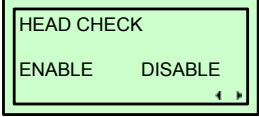
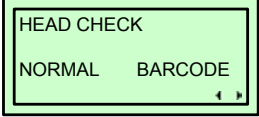
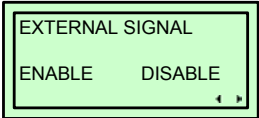
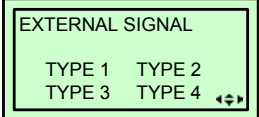

ADVANCED MODE (TABLE 4-2)	
MENU	DESCRIPTION
	<p>Displays the operational status of the printer. The ONLINE status is displayed on the top line and the label quantity status on the bottom. The message will be changed to OFFLINE whenever the printer is switched offline by pressing the LINE key. When a print job is received, the quantity line will indicate the number of labels to be printed. As the label job prints, the display indicates the number of labels remaining to be printed.</p>
	<p>Displays the operational status of the printer. The OFFLINE status is displayed on the top line and the label quantity status on the bottom. The message will be changed to ONLINE whenever the printer is switched online by pressing the LINE key.</p>
	<p>Is a transitional screen that allows the operator to choose a given direction within the menu map.</p>
	<p>Is the entrance screen of the Advanced Mode. The Advanced Mode is provided to make basic printer operational adjustments. Typically, once these adjustments or settings have been made, they will not require additional address unless a new job is downloaded.</p>
	<p>Allows the darkness (print density) selection of the printed image. Has two selection options.</p>

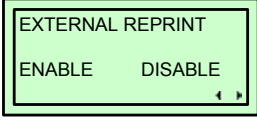
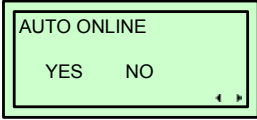
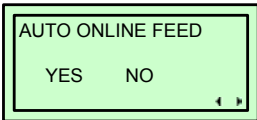
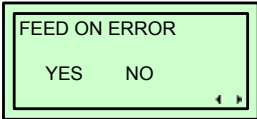
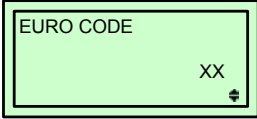
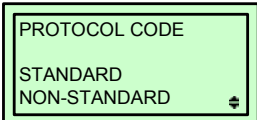

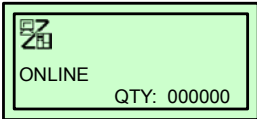
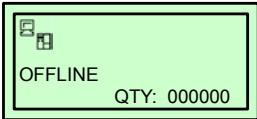
ADVANCED MODE (TABLE 4-2)	
MENU	DESCRIPTION
	Allows the choice of continuous feed or dispenser operation.
	Allows the determination of whether a backfeed motion will be applied. If so, the selection of before or after the printing of each label.
	Allows the printer to be switched to operate in the thermal transfer or direct thermal mode as desired.
	Allows the pitch sensor to be activated or deactivated as circumstances dictate.
	Allows the pitch sensor mode to be selected relative to the media type being used.
	This feature determines the integrity of the print head elements when enabled. The printer will go into error mode when a malfunctioning printhead element is detected.
	This screen will appear if the head check feature has been selected. Choose for the head check to be performed unconditionally or only when barcodes are being printed. Previously printed barcodes should be scanned following an error to determine their functionality.
	Set this feature to enable or disable the printer's external signal communication port. If the port is enabled, data can be sent and received using an appropriate device plugged into the EXT port.
	Appears only if the printer's external signal feature has been enabled to allow selection of the output signal. For information on which type to choose, refer to this printer's Programming Reference for guidance.

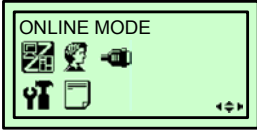
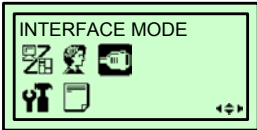
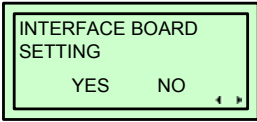
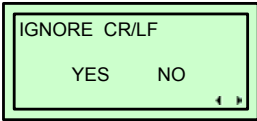
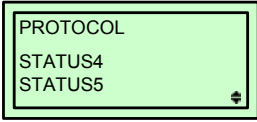
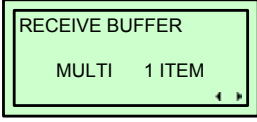
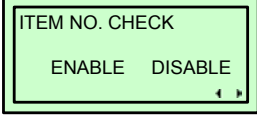
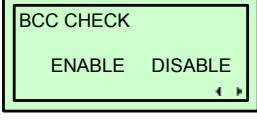
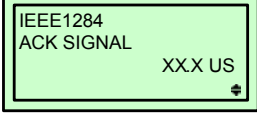
ADVANCED MODE (TABLE 4-2)	
MENU	DESCRIPTION
	Allows configuration as to whether the reprint function may be activated via the external signal port.
	The printer can be set to automatically go into the online mode when powered on. Otherwise, the printer starts in the offline state and must be manually placed online before it is ready to print.
	This feature allows one label to be fed upon the printer entering online mode. Enable or disable as desired.
	This feature allows one label to be fed following an error being corrected and the printer going online.
	Allows the user to specify the hexadecimal code for the character which is replaced with the Euro Character. The default setting should be the correct option.
	The ESC sequence in SBPL (SATO Basic Programming Language) commands may be defined as standard (using non-printable code 1BH) or non-standard (some other user code).

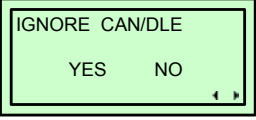
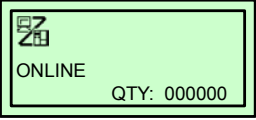
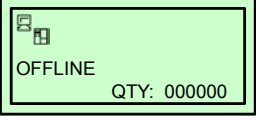
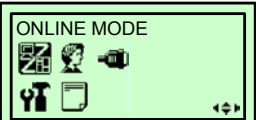
PARALLEL INTERFACE MODE (TABLE 4-3)	
MENU	DESCRIPTION
	Displays the operational status of the printer. The ONLINE status is displayed on the top line and the label quantity status on the bottom. The message will be changed to OFFLINE whenever the printer is switched offline by pressing the LINE key. When a print job is received, the quantity line will indicate the number of labels to be printed. As the label job prints, the display indicates the number of labels remaining to be printed.
	Displays the operational status of the printer. The OFFLINE status is displayed on the top line and the label quantity status on the bottom. The message will be changed to ONLINE whenever the printer is switched online by pressing the LINE key.

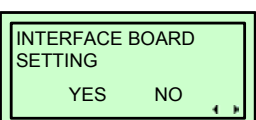
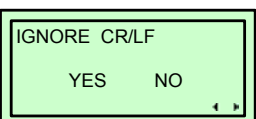
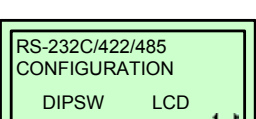
PARALLEL INTERFACE MODE (TABLE 4-3)	
MENU	DESCRIPTION
 <p>ONLINE MODE</p>	Is a transitional screen that allows the operator to choose a given direction within the menu map.
 <p>INTERFACE MODE</p>	Is the premier screen of the Interface Mode. The Interface Mode allows the parameters to be set for the printer to communicate with a host and vice-versa.
 <p>INTERFACE BOARD SETTING</p> <p>YES NO</p>	Select the YES option if an interface board for bi-directional communication will be configured.
 <p>IGNORE CR/LF</p> <p>YES NO</p>	<p>Determines whether the print data code requires deletion. Hexadecimal graphic data will not be deleted. Select YES to delete all carriage return (CR) and line feed (LF) commands in the data stream - including graphics and 2D bar codes.</p> <p>This feature is used primarily to maintain compatibility with earlier models of SATO printers.</p>
 <p>PROTOCOL</p> <p>STATUS4</p> <p>STATUS5</p>	Allows setting of bi-directional communication protocol.
 <p>RECEIVE BUFFER</p> <p>MULTI 1 ITEM</p>	Allows the selection of the receive buffer type. Select MULTI for multi-item buffer and 1ITEM for a single item buffer.
 <p>ITEM NO. CHECK</p> <p>ENABLE DISABLE</p>	Allows item number check to be enabled or disabled. Will only appear when STATUS5 is set for the protocol.
 <p>BCC CHECK</p> <p>ENABLE DISABLE</p>	Allows BCC Check to be enabled or disabled. Will only appear if STATUS5 is set for protocol.
 <p>IEEE1284</p> <p>ACK SIGNAL</p> <p>XX.X US</p>	Allows setting for ACK width of the IEEE1284 interface. The display will appear when the interface is present and one item (1ITEM) is selected as a receive buffer.

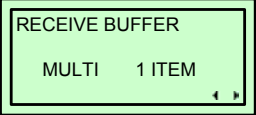
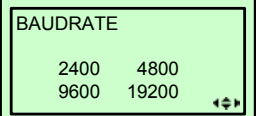
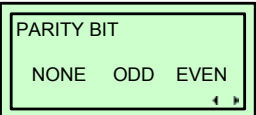
PARALLEL INTERFACE MODE (TABLE 4-3)	
MENU	DESCRIPTION
	<p>Allows 1-byte command such as CAN and DLE code to be deleted. Will only appear when the communication protocol is STATUS4.</p>
SERIAL INTERFACE MODE (TABLE 4-4)	
MENU	DESCRIPTION
	<p>Displays the operational status of the printer. The ONLINE status is displayed on the top line and the label quantity status on the bottom. The message will be changed to OFFLINE whenever the printer is switched offline by pressing the LINE key. When a print job is received, the quantity line will indicate the number of labels to be printed. As the label job prints, the display indicates the number of labels remaining to be printed.</p>
	<p>Displays the operational status of the printer. The OFFLINE status is displayed on the top line and the label quantity status on the bottom. The message will be changed to ONLINE whenever the printer is switched online by pressing the LINE key.</p>
	<p>Is a transitional screen that allows the operator to choose a given direction within the menu map.</p>
	<p>Is the premiere screen of the Interface Mode. The Interface Mode allows the parameters to be set for the printer to communicate with a host and vice-versa.</p>
	<p>Select the YES option if an interface board for bi-directional communication will be configured.</p>
	<p>Determines whether the print data code requires deletion. Hexadecimal graphic data will not be deleted. Select YES to delete all carriage return (CR) and line feed (LF) commands in the data stream - including graphics and 2D bar codes.</p> <p>This feature is used primarily to maintain compatibility with earlier models of SATO printers.</p>
	<p>Selection of the DIPSW option will use settings on the RS232C card. The LCD option advances the operator to menus that allow the DIPSW settings to be over-written.</p>

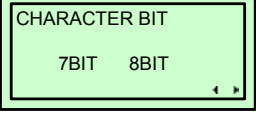
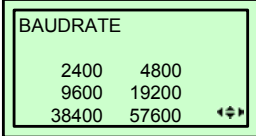
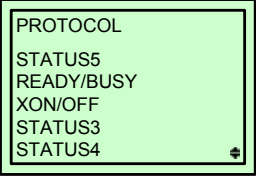
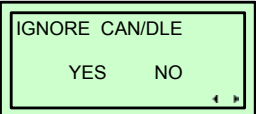

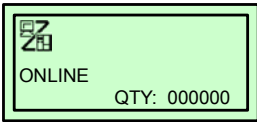
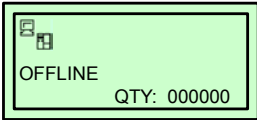
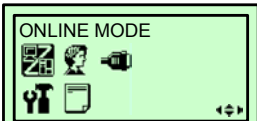
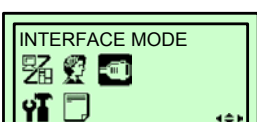
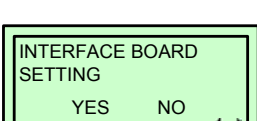
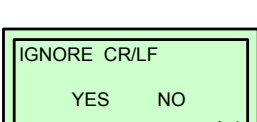
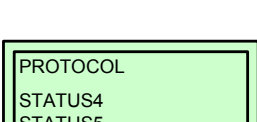
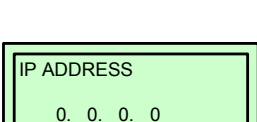
SERIAL INTERFACE MODE (TABLE 4-4)	
MENU	DESCRIPTION
	Allows the selection of the receive buffer type. Select MULTI for multi-item buffer and 1ITEM for a single item buffer.
	Allows selection of the baud rate. Will only appear when the RS232C interface is installed and the LCD option is chosen from the prior menu.
	Allows setting of the parity bit for the serial interface. Will not display if the dipswitch priority option is chosen. The interface board must be installed.
	Allows stop bit selection for the serial interface. Will not display if the dipswitch priority option is chosen.
	Allows selection of the data length for serial interface. Will not display if the dipswitch priority option is chosen.
	Allows selection of the baud rate. Will only appear when the RS422 or RS485 interface is installed and the LCD option is chosen from the prior menu.
	Allows setting of communication protocol.
	Allows 1-byte command such as CAN and DLE code to be deleted. Will only appear when the communication protocol is STATUS4 (for overseas specifications).

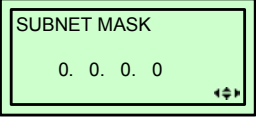
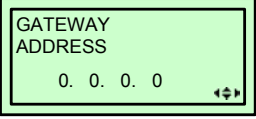
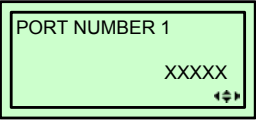
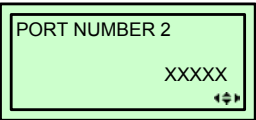
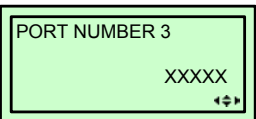
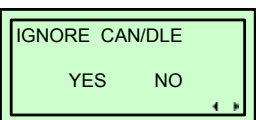
LAN INTERFACE MODE (TABLE 4-5)	
MENU	DESCRIPTION
	<p>Displays the operational status of the printer. The ONLINE status is displayed on the top line and the label quantity status on the bottom. The message will be changed to OFFLINE whenever the printer is switched offline by pressing the LINE key. When a print job is received, the quantity line will indicate the number of labels to be printed. As the label job prints, the display indicates the number of labels remaining to be printed.</p>
	<p>Displays the operational status of the printer. The OFFLINE status is displayed on the top line and the label quantity status on the bottom. The message will be changed to ONLINE whenever the printer is switched online by pressing the LINE key.</p>
	<p>Is a transitional screen that allows the operator to choose a given direction within the menu map.</p>
	<p>Is the premier screen of the Interface Mode. The Interface Mode allows the parameters to be set for the printer to communicate with a host and vice-versa.</p>
	<p>Select the YES option if an interface board for bi-directional communication will be configured.</p>
	<p>Determines whether the print data code requires deletion. Hexadecimal graphic data will not be deleted. Select YES to delete all carriage return (CR) and line feed (LF) commands in the data stream - including graphics and 2D bar codes.</p> <p>This feature is used primarily to maintain compatibility with earlier models of SATO printers.</p>
	<p>Allows setting of the sequence of control characters to ensure correct data transference. See your Network Administrator to find out which Status number will be used for the control characters being sent to and from the printer.</p>
	<p>Sets a unique static IP Address using the TCP/IP Protocol. The format of an IP Address is a 32-bit numeric address written as four numbers separated by periods. See your Network Administrator for available IP Addresses.</p>

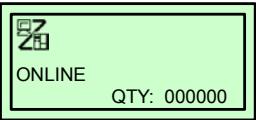
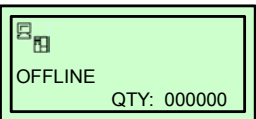
LAN INTERFACE MODE (TABLE 4-5)	
MENU	DESCRIPTION
	Specifies which segment of the network the printer will reside. The format of Subnet Mask is a 32-bit numeric address written as four numbers separated by periods. See your Network Administrator to find out your Subnet Mask.
	Specifies the IP Address of the main router on the host network. The format of a Gateway Address is a 32-bit numeric address written as four numbers separated by periods. See your Network Administrator to find out your Default Gateway Address.
	Sets the primary layer interface that enables data transfer to and from the printer. See you Network Administrator to find out what your default primary port number should be.
	Sets the secondary layer interface that enables data transfer to and from the printer. See you Network Administrator to find out what your default secondary port number should be.
	Sets the tertiary layer interface that enables data transfer to and from the printer. See you Network Administrator to find out what your default tertiary port number should be.
	Allows 1-byte command such as CAN and DLE code to be deleted. Will only appear when the communication protocol is STATUS4.

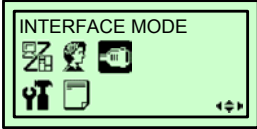
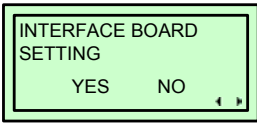
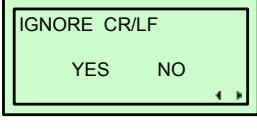
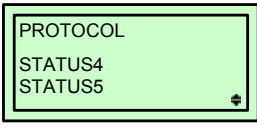
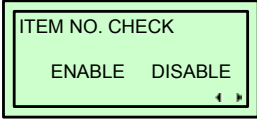
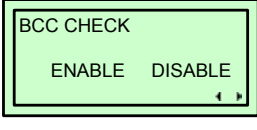
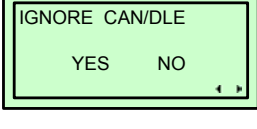
USB INTERFACE MODE (TABLE 4-6)	
MENU	DESCRIPTION
	Displays the operational status of the printer. The ONLINE status is displayed on the top line and the label quantity status on the bottom. The message will be changed to OFFLINE whenever the printer is switched offline by pressing the LINE key. When a print job is received, the quantity line will indicate the number of labels to be printed. As the label job prints, the display indicates the number of labels remaining to be printed.
	Displays the operational status of the printer. The OFFLINE status is displayed on the top line and the label quantity status on the bottom. The message will be changed to ONLINE whenever the printer is switched online by pressing the LINE key.

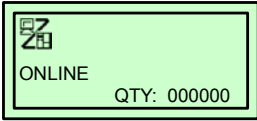
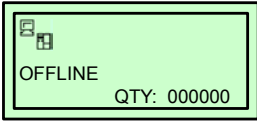
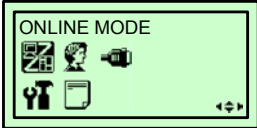
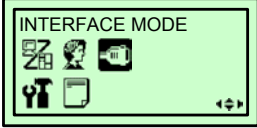
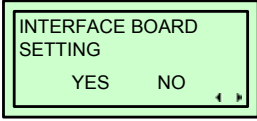
USB INTERFACE MODE (TABLE 4-6)	
MENU	DESCRIPTION
 <p>ONLINE MODE</p>	Is a transitional screen that allows the operator to choose a given direction within the menu map.
 <p>INTERFACE MODE</p>	Is the premier screen of the Interface Mode. The Interface Mode allows the parameters to be set for the printer to communicate with a host and vice-versa.
 <p>INTERFACE BOARD SETTING</p> <p>YES NO</p>	Select the YES option if an interface board for bi-directional communication will be configured.
 <p>IGNORE CR/LF</p> <p>YES NO</p>	Determines whether the print data code requires deletion. Hexadecimal graphic data will not be deleted. Select YES to delete all carriage return (CR) and line feed (LF) commands in the data stream - including graphics and 2D bar codes. This feature is used primarily to maintain compatibility with earlier models of SATO printers.
 <p>PROTOCOL</p> <p>STATUS4</p> <p>STATUS5</p>	Allows setting of communication protocol.
 <p>ITEM NO. CHECK</p> <p>ENABLE DISABLE</p>	Allows item number check to be enabled or disabled. Will only appear when STATUS5 is set for the protocol.
 <p>BCC CHECK</p> <p>ENABLE DISABLE</p>	Allows BCC Check to be enabled or disabled. Will only appear if STATUS5 is set for protocol.
 <p>IGNORE CAN/DLE</p> <p>YES NO</p>	Allows 1-byte command such as CAN and DLE code to be deleted. Will only appear when the communication protocol is STATUS4.

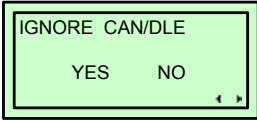
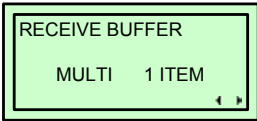

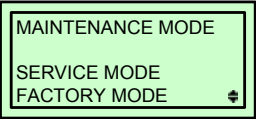
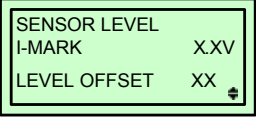
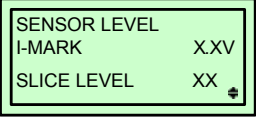
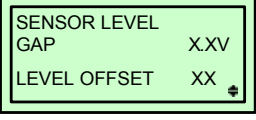
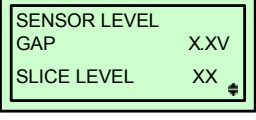
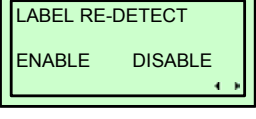
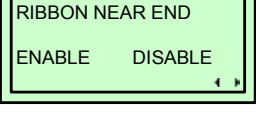
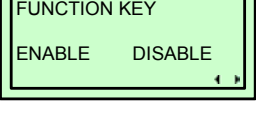
CENTRONICS INTERFACE MODE (TABLE 4-7)	
MENU	DESCRIPTION
	<p>Displays the operational status of the printer. The ONLINE status is displayed on the top line and the label quantity status on the bottom. The message will be changed to OFFLINE whenever the printer is switched offline by pressing the LINE key. When a print job is received, the quantity line will indicate the number of labels to be printed. As the label job prints, the display indicates the number of labels remaining to be printed.</p>
	<p>Displays the operational status of the printer. The OFFLINE status is displayed on the top line and the label quantity status on the bottom. The message will be changed to ONLINE whenever the printer is switched online by pressing the LINE key.</p>
	<p>Is a transitional screen that allows the operator to choose a given direction within the menu map.</p>
	<p>Is the premier screen of the Interface Mode. The Interface Mode allows the parameters to be set for the printer to communicate with a host and vice-versa.</p>
	<p>Select the YES option if an interface board for bi-directional communication will be configured.</p>
	<p>Determines whether the print data code requires deletion. Hexadecimal graphic data will not be deleted. Select YES to delete all carriage return (CR) and line feed (LF) commands in the data stream - including graphics and 2D bar codes.</p> <p>This feature is used primarily to maintain compatibility with earlier models of SATO printers.</p>
	<p>Allows 1-byte command such as CAN and DLE code to be deleted. Will only appear when the communication protocol is STATUS4 (for overseas specifications).</p>
	<p>Allows the selection of the receive buffer type. Select MULTI for multiple buffers and 1ITEM for a single item buffer.</p>

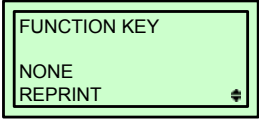
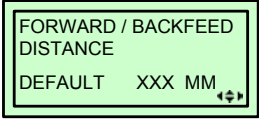
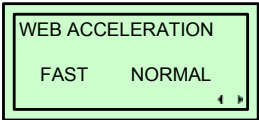
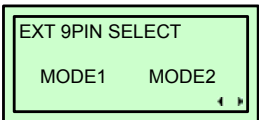
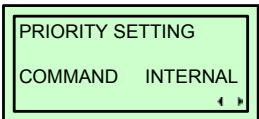
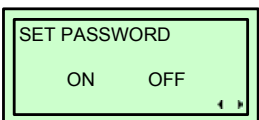
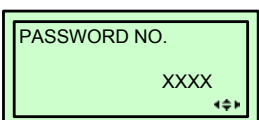
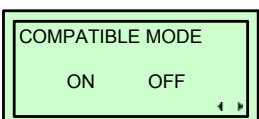
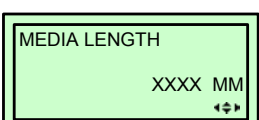
SERVICE MODE (TABLE 4-8)	
MENU	DESCRIPTION
 <pre> MAINTENANCE MODE SERVICE MODE FACTORY MODE </pre>	<p>The Maintenance Mode is divided into two sections; the Service Mode and the Factory Mode.</p> <p>The Service Mode allows the programming of various dimensional settings, sensor thresholds, and language options.</p> <p>The Factory Mode permits counter reset of various printer components. Use the printer's operator panel to select and reset those features.</p>
 <pre> SENSOR LEVEL I-MARK X.XV LEVEL OFFSET XX </pre>	Allows sensitivity adjustment of the eye-mark sensor.
 <pre> SENSOR LEVEL I-MARK X.XV SLICE LEVEL XX </pre>	Allows slice level adjustment of the eye-mark sensor.
 <pre> SENSOR LEVEL GAP X.XV LEVEL OFFSET XX </pre>	Allows sensitivity adjustment of the gap sensor.
 <pre> SENSOR LEVEL GAP X.XV SLICE LEVEL XX </pre>	Allows slice level adjustment of the gap sensor.
 <pre> LABEL RE-DETECT ENABLE DISABLE </pre>	Select the ENABLE option to set the printer to automatically notify when media supply is nearly exhausted.
 <pre> RIBBON NEAR END ENABLE DISABLE </pre>	Select the ENABLE option to set the printer to automatically notify when ribbon supply is nearly exhausted.
 <pre> FUNCTION KEY ENABLE DISABLE </pre>	Allows the operator to select to use a function key or not. If enable is selected, the following menu will appear.

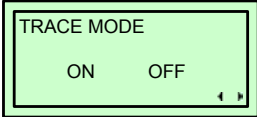
SERVICE MODE (TABLE 4-8)	
MENU	DESCRIPTION
	Allows the option of reprinting a label with key or not.
	Allows the backfeed distance to be set. If using thermal transfer for printing, set the feed distance less than 30mm to avoid detection of the ribbon end by accident.
	Allows the printer to use either a NORMAL or FAST web acceleration. Large, heavy, label rolls should use the NORMAL option while smaller, lighter rolls can use the FAST option.
	Allows selection of output mode options. MODE1 outputs signal in the status of existence/non-existence for the number of remaining labels to be printed. MODE2 outputs signal in the status of online/offline.
	Allows the user to assign a method a command priority. Where programming instructions conflict, the printer will allow this assignment to take priority. This priority assignment affects the settings for print darkness, print speed, start point correction, operation mode, print method, and sensor types.
	Allows the password function to enabled (ON) or disabled (OFF).
	This screen will appear if the ON option was selected in the previous screen. Use the arrow keys to scroll and enter a four-digit password.
	Determines whether or not the printer will be compatible with a previous printer model.
	Enables the length of the label stock installed to be manually entered.

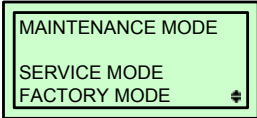
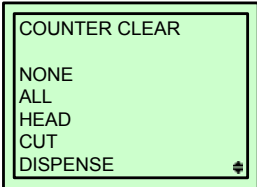
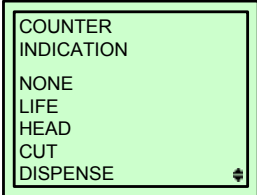
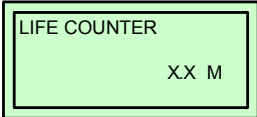
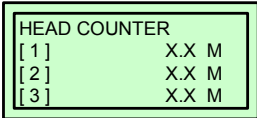
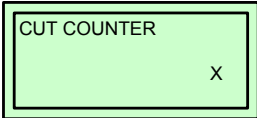

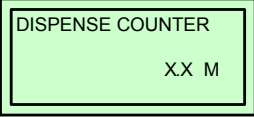
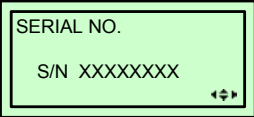
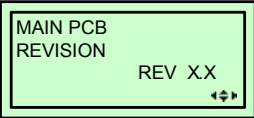
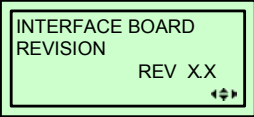
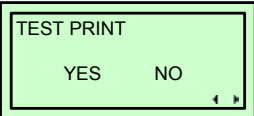
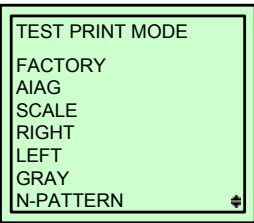
SERVICE MODE (TABLE 4-8)	
MENU	DESCRIPTION
	<p>When enabled (ON), the printer's status (receiving, editing, printing) will be displayed as an icon. Disabled (OFF) conversely, does not.</p>

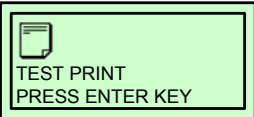
FACTORY MODE (TABLE 4-9)	
MENU	DESCRIPTION
	<p>The Maintenance Mode is divided into two sections; the Service Mode and the Factory Mode.</p> <p>The Factory Mode permits counter reset of various printer components. Use the printer's operator panel to select and reset those features.</p> <p>The Service Mode allows the programming of various dimensional settings, sensor thresholds, and language options.</p>
	<p>Enables the printer's internal counter to be initiated and reset.</p>
	<p>Allows view of the recorded linear meters of printed media by the printer's internal counters.</p>
	<p>Enables view of the printer's internal life counter.</p>
	<p>Displays values for the head counter.</p>
	<p>This printer does not have a cutter assembly, thusly this screen should be ignored.</p>

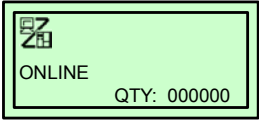
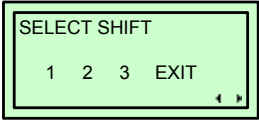
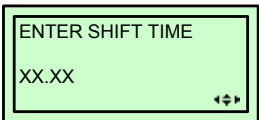
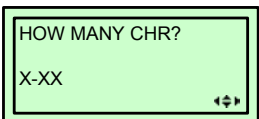
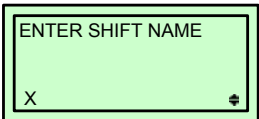
FACTORY MODE (TABLE 4-9)	
MENU	DESCRIPTION
	This printer does not have a dispenser assembly, thusly this screen should be ignored.
	Enables the printer's serial number to be recorded within its memory.
	Enables the revision number of the main circuit board to be recorded within its memory.
	Enables the revision number of the interface board to be recorded within its memory.
	Initiates test printing.
	If the YES option is select from the previous screen, this menu allows the test print type to be selected.
	Enables the print size to be selected.
	Initiates test printing activity.

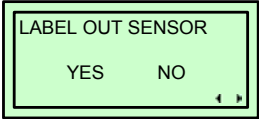
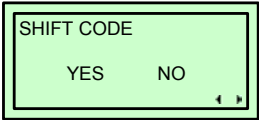
WORK SHIFT MODE (TABLE 4-10)	
MENU	DESCRIPTION
	<p>Displays the operational status of the printer. The ONLINE status is displayed on the top line and the label quantity status on the bottom. The message will be changed to OFFLINE whenever the printer is switched offline by pressing the LINE key. When a print job is received, the quantity line will indicate the number of labels to be printed. As the label job prints, the display indicates the number of labels remaining to be printed.</p>
	<p>This screen is used to select the shift that will be configured in the screens to follow. Up to 3 shift can be configured.</p>
	<p>Permits the entry of the begin time of the shift being configured. This is a 24 hour clock format.</p>
	<p>Allows the establishment of the quantity of characters to be used for the Shift Name in the screen to follow. The first X depicts the shift number and is based upon what was selected in the Select Shift screen. The XX has valid range of 1 to 16.</p>
	<p>Allows the entry of the user defined shift name. The quantity of characters used must be reflective of the quantity entered in the preceding screen.</p>

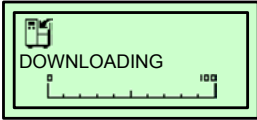
HIDDEN MODE (TABLE 4-11)	
MENU	DESCRIPTION
	<p>Used to enable or disable the label out sensor. The YES option is enabled and the NO option is disabled.</p>
	<p>Used to enable or disable the Shift Code menu parameters. The YES option is enabled and the NO option is disabled. Note the YES option must be selected to access the Work Shift Mode menu.</p>

DOWNLOAD MODE (TABLE 4-12)	
MENU	DESCRIPTION
	Confirms the printer is on standby for receiving the downgrade or upgrade of Firmware from the host.
	Downloading progress may be monitored here. Entry is not required at this screen. Press the CANCEL key located on the operator panel to abort downloading.
	Displays when the download process is complete. Press the ENTER key located on the operator panel to exit.

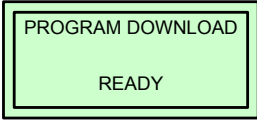
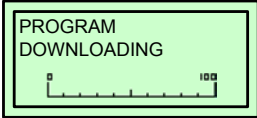
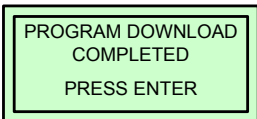
BOOT DOWNLOAD MODE (TABLE 4-13)	
MENU	DESCRIPTION
	Confirms the printer is on standby for receiving Firmware download.
	Downloading progress may be monitored here. Entry is not required at this screen. Press the CANCEL key located on the operator panel to abort downloading.
	Displays when the program download process is complete. Press the ENTER key located on the operator panel to exit.

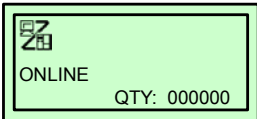
PRINT CANCEL MODE (TABLE 4-14)	
MENU	DESCRIPTION
	Displays the operational status of the printer. The ONLINE status is displayed on the top line and the label quantity status on the bottom. The message will be changed to OFFLINE whenever the printer is switched offline by pressing the LINE key. When a print job is received, the quantity line will indicate the number of labels to be printed. As the label job prints, the display indicates the number of labels remaining to be printed.

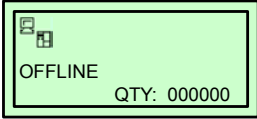
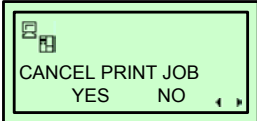
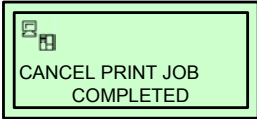
PRINT CANCEL MODE (TABLE 4-14)	
MENU	DESCRIPTION
 <p>OFFLINE QTY: 000000</p>	Displays the operational status of the printer. The OFFLINE status is displayed on the top line and the label quantity status on the bottom. The message will be changed to ONLINE whenever the printer is switched online by pressing the LINE key.
 <p>CANCEL PRINT JOB YES NO</p>	Print data that has been previously received, can be cleared. If YES is selected, the print data will be deleted and then the printer will go offline. If the NO option is selected, the printer will go offline without deleting data.
 <p>CANCEL PRINT JOB COMPLETED</p>	This screen indicates that the received data has been deleted. Will display for 3 seconds and then the printer will go offline.

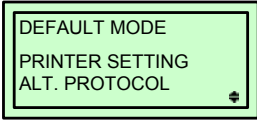
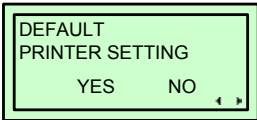
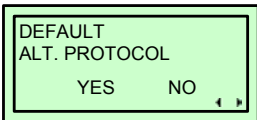
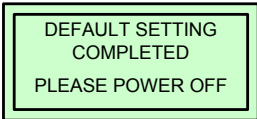
DEFAULT SETTINGS MODE (TABLE 4-15)	
MENU	DESCRIPTION
 <p>DEFAULT MODE PRINTER SETTING ALT. PROTOCOL</p>	Allows printer settings and/or protocols to be returned to the factory default settings.
 <p>DEFAULT PRINTER SETTING YES NO</p>	Initiates the return to printer setting defaults.
 <p>DEFAULT ALT. PROTOCOL YES NO</p>	Confirm initialization of protocol code defaults.
 <p>DEFAULT SETTING COMPLETED PLEASE POWER OFF</p>	Confirms the completion of printer default settings.

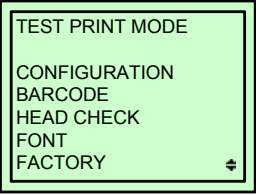
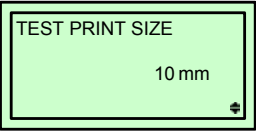
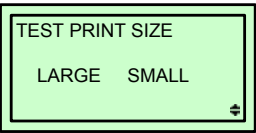
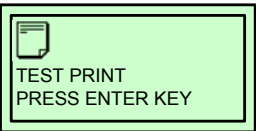
TEST PRINT MODE (TABLE 4-16)	
MENU	DESCRIPTION
	<p>Is the initial screen of the Test Print Mode.</p> <ul style="list-style-type: none"> • Configuration: The printer's configuration settings. • Barcode: The printer's installed barcodes. • Head Check: A pattern to check print head elements. • Font: The contents of the installed fonts. • Factory: A factory test label will be printed.
	<p>This screen only appears if Configuration, Barcode, or Head Check was chosen in the previous menu. The increments of measure are 1cm.</p>
	<p>For factory test prints, this screen appears instead of the previous screen for setting print size. Large (10cm) and small (4cm) print sizes are the only two options.</p>
	<p>Pressing ENTER will indicate continuous test printing. Pressing ENTER again will suspend printing. If the external signal is enabled, the test print must be initiated with a print start signal via the EXT port.</p>

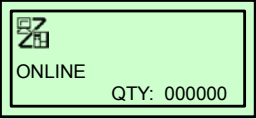
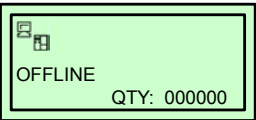
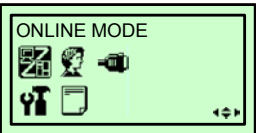
HEX DUMP MODE (TABLE 4-17)	
MENU	DESCRIPTION
	<p>Displays the operational status of the printer. The ONLINE status is displayed on the top line and the label quantity status on the bottom. The message will be changed to OFFLINE whenever the printer is switched offline by pressing the LINE key. When a print job is received, the quantity line will indicate the number of labels to be printed. As the label job prints, the display indicates the number of labels remaining to be printed.</p>
	<p>Displays the operational status of the printer. The OFFLINE status is displayed on the top line and the label quantity status on the bottom. The message will be changed to ONLINE whenever the printer is switched online by pressing the LINE key.</p>
	<p>Is a transitional screen that allows the operator to choose a given direction within the menu map.</p>

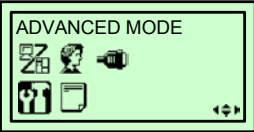
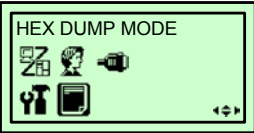
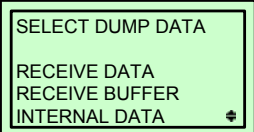
HEX DUMP MODE (TABLE 4-17)	
MENU	DESCRIPTION
	<p>The Advanced Mode screen is only a transitional screen to the Hex Dump Mode screen.</p>
	<p>Is the premiere screen to the Hex Dump Mode. The contents of the print buffer and the data received before it is placed into the print buffer may be examined through the use of the Hex Dump Mode.</p> <p>Each line of the printed data is enumerated in the first column, the second column contains the data in hexadecimal format, and the right column contains the same data in ASCII format.</p>
	<p>Only one type of data will be printed at a time. This screen allows the selection of the data to be printed. Repeat the Hex Dump process to print the other types of data if required.</p> <p>Internal Data is to print the settings for the internal buffer.</p>







5

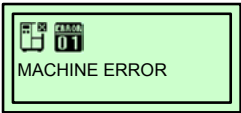
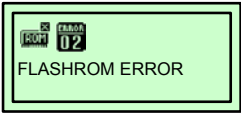

TROUBLESHOOTING

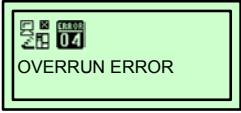



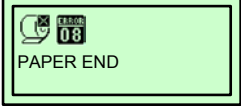

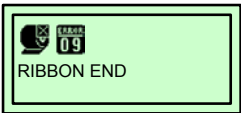
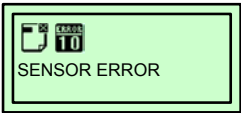
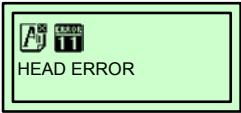
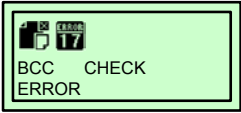

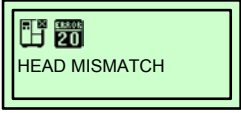
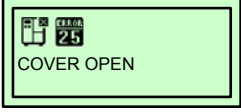



- **Error Signal Troubleshooting**
- **Warning Signal Troubleshooting**
- **Troubleshooting Table**
- **Interface Troubleshooting**
- **Test Print Modes**

ERROR SIGNAL TROUBLESHOOTING

This chapter identifies the printer's various LCD error signals and their relative audible alarms, as well as, their probable causes and remedies for problem resolution.





ERROR DISPLAYS			
ERROR	LED CONDITION	LCD DISPLAY	DESCRIPTION
01 Machine Error	POWER: On ONLINE: Off LABEL: Off RIBBON: Off		<ol style="list-style-type: none"> 1. Ensure all wiring harnesses are properly connected. 2. Replace main circuit board.
02 Flash ROM Error	POWER: On ONLINE: Off LABEL: Off RIBBON: Off		<ol style="list-style-type: none"> 1. Ensure correct communication protocols. 2. Check cables, cycle printer power and resend. 3. Replace board.
03 Parity Error	POWER: On ONLINE: Off LABEL: Off RIBBON: Off		<ol style="list-style-type: none"> 1. Ensure correct communication parameters. 2. Check cables, cycle printer and resend. 3. Replace board.
04 Overrun Error	POWER: On ONLINE: Off LABEL: Off RIBBON: Off		<ol style="list-style-type: none"> 1. Check and correct communication cables and settings.
05 Framing Error	POWER: On ONLINE: Off LABEL: Off RIBBON: Off		<ol style="list-style-type: none"> 1. Ensure host system and interface settings match. 2. Check and correct communication cables. (null modem serial cable required)
06 Buffer Overflow Error	POWER: On ONLINE: Off LABEL: Off RIBBON: Off		<ol style="list-style-type: none"> 1. Size of received data exceeds size of receiving buffer. 2. Establish the correct communication protocol.
07 Head Open Error	POWER: On ONLINE: Off LABEL: Off RIBBON: Off		<ol style="list-style-type: none"> 1. Properly latch the print head. 2. Replace the head-open switch.
08 Paper End Error	POWER: On ONLINE: Off LABEL: On RIBBON: Off		<ol style="list-style-type: none"> 1. Ensure media is properly loaded. 2. Clean sensor transmit/receive surfaces. 3. Ensure correct sensor configuration.

ERROR DISPLAYS			
ERROR	LED CONDITION	LCD DISPLAY	DESCRIPTION
09 Ribbon End Error	POWER: On ONLINE: Off LABEL: Off RIBBON: On		<ol style="list-style-type: none"> 1. Ensure ribbon stock is properly loaded. 2. Ensure ribbon has not been damaged. 3. Ensure proper printer configuration.
10 Sensor Error	POWER: On ONLINE: Off LABEL: Off RIBBON: Off		<ol style="list-style-type: none"> 1. Ensure media is properly loaded. 2. Clean sensor transmit/receive surfaces. 3. Ensure correct sensor configuration. 4. Replace sensor as necessary.
11 Head Related Error	POWER: On ONLINE: Off LABEL: Off RIBBON: Off		<ol style="list-style-type: none"> 1. Clean the print head's contact surface. 2. Replace the print head.
17 Memory Reading Error	POWER: On ONLINE: Off LABEL: Off RIBBON: Off		<ol style="list-style-type: none"> 1. Delete unnecessary data to free up memory space. 2. Ensure the data communication settings are correct.
18 Item Number Error	POWER: On ONLINE: Off LABEL: Off RIBBON: Off		<ol style="list-style-type: none"> 1. Data sequence number doesn't match previous data. 2. Check send data and communications setting.
20 Head Mismatch Error	POWER: On ONLINE: Off LABEL: Off RIBBON: Off		<ol style="list-style-type: none"> 1. Reinstall print head. 2. Ensure proper print head is installed.
25 Cover Open Error	POWER: On ONLINE: Off LABEL: Off RIBBON: On		<ol style="list-style-type: none"> 1. Ensure cover is fully closed. 2. Replace cover-open sensor.

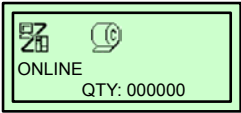
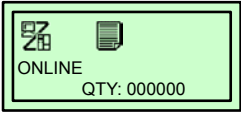
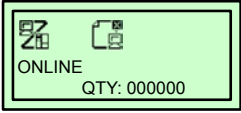
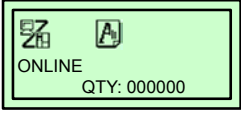
ERROR ICONS		
LCD ICONS	DESCRIPTION OF ERROR	POSITION ON LCD
	Displayed when detecting Label End.	Icon 1
	Displayed when detecting Ribbon End.	Icon 1
	Displayed when detecting Sensor Error.	Icon 1
	Displayed when detecting Head Open.	Icon 1
	Displayed when head is disconnected.	Icon 1
	Displayed when detecting Communication Error.	Icon 1
	Displayed when detecting Receive Buffer Over.	Icon 1
	Displayed when detecting Item No. Error or BCC Error.	Icon 1
	Displayed when having write failure to main ROM.	Icon 1
	Displayed when detecting Calendar Error.	Icon 1
	Displayed when printer error other than above is detected.	Icon 1
	Displayed error number corresponding to various errors.	Icon 2

WARNING SIGNAL TROUBLESHOOTING

WARNING DISPLAYS			
WARNING	LED CONDITION	LCD DISPLAY	DESCRIPTION
01 Ribbon Near-End Warning	POWER: On ONLINE: On LABEL: On RIBBON: Off		<ol style="list-style-type: none"> Limited media quantity remaining. Monitor and reload before all is used.
03 Receive Buffer Near-Full Warning	POWER: On ONLINE: On LABEL: Off RIBBON: Off		<ol style="list-style-type: none"> Little receive buffer capacity remaining. Cease data transmission until existing data is analyzed.
04 Command Error Warning	POWER: On ONLINE: On LABEL: Off RIBBON: Off		<ol style="list-style-type: none"> Review print data for command error.
05 Head Error Warning	POWER: On ONLINE: On LABEL: Off RIBBON: Off		<ol style="list-style-type: none"> Ensure print head is connected. Replace print head.

WARNING ICONS		
ICON	DESCRIPTION	POSITION ON LCD
	Displayed when detecting Ribbon Near End.	Icon 3 to 5
	Displayed when detecting Command Error.	Icon 3 to 5
	Displayed when detecting Buffer Near Full.	Icon 3 to 5
	Displayed when head is disconnected.	Icon 3 to 5

TROUBLESHOOTING TABLE

TROUBLESHOOTING TABLE	
IMAGE VOIDS	
Dirty print head.	Clean print head.
Damaged print head.	Replace print head.
Damaged electronics.	Replace circuit board.
Damaged or worn roller.	Replace rollers.
Poor label quality.	Use higher quality media.
Ribbon stock and media are mismatched.	Consult with media supplier.
RIBBON WRINKLING	
Poor head alignment.	Adjust head balance and alignment.
Excessive temperature setting	Adjust temperature.
Poor ribbon tension.	Adjust tension as required.
Worn roller.	Replace as necessary.
Foreign material on print head and/or rollers.	Clean as required.
Foreign material on labels.	Use higher quality media.
Damaged print head.	Replace print head as required.
LIGHT PRINT IMAGES	
Low print head energy/darkness.	Adjust darkness level.
Low print head pressure.	Adjust head pressure and/or balance.
Foreign material on print head.	Clean print head and rollers.
Improper head alignment.	Align print head as required.
Excessive print speed.	Reduce print speed setting.
UNEVEN PRINT DARKNESS	
Unbalanced print head.	Adjust head balance.
Worn rollers.	Replace rollers as required.
Dirty print head.	Clean print head.
MEANDERING MEDIA	
Incorrectly loaded media.	Ensure correct loading.
Improperly adjusted media guides.	Adjust as required.
Unbalanced print head.	Adjust as required.
Worn rollers.	Replace as required.
NO LABEL MOVEMENT	
Loose or broken timing belt.	Replace or adjust as required.
Incorrect label sensor selected.	Check printer configuration for proper sensor selection.
No voltage output.	Replace fuse. Test power supply and replace as required.
Drive motor not operating.	Ensure wiring harness connection. Replace as necessary.
LCD FIELD ILLUMINATED BUT WITHOUT WORDS OR NO DISPLAY AT ALL	
Power supply issues.	Ensure cable properly connected. Check/replace power supply.
Incorrectly positioned display potentiometer.	Adjust as required.

NO PRINTED IMAGE	
Print head is disconnected.	Ensure print head wiring harness is connected on each end.
No voltage output.	Replace fuse. Test power supply and replace as required.
Defective print head.	Replace print head and reset counter.
Damaged electronics.	Replace circuit board.
Interface problems.	Troubleshoot interface - refer to the next chapter.
Data input error.	Ensure correct data stream.
PRINTER CREATES A BLANK LABEL.	
Data input error.	Ensure correct data stream.
Incorrect label sensor selection.	Ensure correct printer configuration.
Disconnected print head.	Power off the printer and ensure a proper connection.
Defective print head.	Replace print head as required.
Defective main circuit board.	Replace main board as required.
INCORRECT LABEL POSITIONING.	
Incorrect label sensor selection.	Ensure correct printer configuration.
Improper sensor adjustment.	Adjust sensor sensitivity as required.
Data input error.	Ensure correct data stream.
Incorrect offset settings.	Adjust settings as required.
Incorrect applicator setup.	Refer to applicator documentation or contact manufacturer.
SMEARED PRINT IMAGES	
Poor media quality.	Use higher quality media.
Foreign material on print head and platen roller.	Clean print head and rollers.
Foreign material on labels.	Use higher quality media.
Excessive print head energy.	Adjust darkness setting.
Excessive print speed.	Adjust print speed as required.

INTERFACE TROUBLESHOOTING

This chapter provides a checklist for the various interface types. Locate the checklist relative to the interface used and perform each of the troubleshooting tasks until the problem has been isolated.

PARALLEL INTERFACE	
CHK	TROUBLESHOOTING STEP
	Ensure the interface module is correctly installed. Run self-test to verify.
	Ensure the printer cable is connected to the appropriate LPT port on the host computer. If using a Windows printer driver, ensure the correct port is selected.
	Ensure a IEEE1284 printer cable is being used.
	Ensure the host's peripheral settings are set to ECP for faster throughput. Refer to the computer manufacturer's documentation for details.
	Ensure the printer is receiving information from the computer using the Receive Buffer Hex Dump mode. Refer to that procedure within this manual for instructions. The command stream should be continuous and possess 0Dhex and/or 0Ahex (carriage return and line feed) characters throughout. However, there should not be either located between the start (<ESC>A and the stop (<ESC>Z) commands.
	Replace the interface board with another to isolate the problem.
	Replace the interface board permanently if determined to be the problem.

RS232 SERIAL INTERFACE	
CHK	TROUBLESHOOTING STEP
	Ensure the correct interface module is correctly installed. Run self-test to verify.
	Ensure the serial cable (Null Modem) meets specifications and is correctly connected at each end.
	Ensure the serial cable is not defective.
	Ensure the communication parameters for the baud rate, parity, data bits and stop bits are consistent with those being sent from the host computer.
	Ensure the printer is receiving information from the computer using the Receive Buffer Hex Dump mode. Refer to that procedure within this manual for instructions. The command stream should be continuous and possess 0Dhex and/or 0Ahex (carriage return and line feed) characters throughout. However, there should not be either located between the start (<ESC>A and the stop (<ESC>Z) commands.
	Replace the interface board with another to isolate the problem.
	Replace the interface board permanently if determined to be the problem.

UNIVERSAL SERIAL BUS (USB) INTERFACE	
If nothing prints during a test print, verify the device drivers have been successively installed by performing the following:	
	Click on Start, Settings, and then Control Panel.
	Click on System within the new window.
	Click on the Device Manager tab.
	Ensure that the View Device By Type is checked.
	Scroll to SATO-USB Device and ensure that errors do not exist. Reinstall as required.
	Reboot the PC and the printer.
	Contact Microsoft technical support for further assistance as required.

LAN ETHERNET INTERFACE	
CHK	TROUBLESHOOTING STEP
	Ensure the interface has been correctly configured. Wait two minutes and run self-test to verify. If a test label does not print, there may be a hardware problem.
	Ensure the cable and its ports are not defective.
	Ensure that a faulty print server or other protocol related scenarios are not creating a queue setup issue. Systematically perform checks and tests to isolate the cause.
	If using TCP/IP, ensure a valid IP address is specified and that all parameters are correct (subnet mask, gateway, etc.). Attempt to PING the IP address assigned to the network interface.
	If using a repeater or hub, ensure the SQE is turned off. Also ensure the repeater port is not defective by trying the print server on another port.
	Install the IPX/SPX protocol on a workstation to determine if the network device can be discovered via the MAC address. If able, configure the appropriate protocols and retest connectivity.
	Use a crossover cable to isolate the printer from the network by connecting from the interface and workstation. Verify that the parameters match on each. Test connectivity.

WIRELESS LAN INTERFACE	
CHK	TROUBLESHOOTING STEP
	Ensure the interface module is correctly installed. Run self-test to verify.
	Check the signal strength by the three LED's on the interface. The more LED's are illuminated green, the stronger the signal.
	Ensure the printer is receiving information from the computer using the Receive Buffer Hex Dump mode. Refer to that procedure within this manual for instructions. The command stream should be continuous and possess 0Dhex and/or 0Ahex (carriage return and line feed) characters throughout. However, there should not be either located between the start (<ESC>A and the stop (<ESC>Z) commands.
	Ensure the interface has been correctly configured. Wait two minutes and run self-test to verify. If a test label does not print, there may be a hardware problem.
	If using TCP/IP, ensure a valid IP address is specified and that all parameters are correct (subnet mask, gateway, etc.). Attempt to PING the IP address assigned to the network interface. Also ensure the SSID, channel, and security matches that of the network.
	Install the IPX/SPX protocol on a workstation to determine if the network device can be discovered via the MAC address. If able, configure the appropriate protocols and retest connectivity.
	Replace the interface board with another to isolate the problem.
	Replace the interface board permanently if determined to be the problem. Also reset the interface card.

CENTRONICS INTERFACE	
CHK	TROUBLESHOOTING STEP
	Ensure the interface module is correctly installed. Run self-test to verify.
	Ensure the printer cable is connected to the appropriate LPT port on the host computer. If using a Windows printer driver, ensure the correct port is selected.
	Ensure the host's peripheral settings are set for Centronics output for faster throughput. Refer to the computer manufacturer's documentation for details.
	Ensure the printer is receiving information from the computer using the Receive Buffer Hex Dump mode. Refer to that procedure within this manual for instructions. The command stream should be continuous and possess 0Dhex and/or 0Ahex (carriage return and line feed) characters throughout. However, there should not be either located between the start (<ESC>A and the stop (<ESC>Z) commands.
	Replace the interface board with another to isolate the problem - permanently replace if defective.

TEST PRINT TROUBLESHOOTING

Chapter provides instruction on special printing to identify and resolve specific print problems.

- HEX DUMP** Allows the operator to determine if there were problems in the downloading of data.
- TEST LABEL** Allows the operator to identify specific problems regarding mechanical performance and setup.

HEX DUMP MODE

The contents of the print buffer can be examined using the Hex Dump Mode. In the left column, each line of data received is numbered. The center column provides the data in hexadecimal format. And in the right column, same data is provided in the ASCII format. Follow the flow chart provided below to perform this activity.

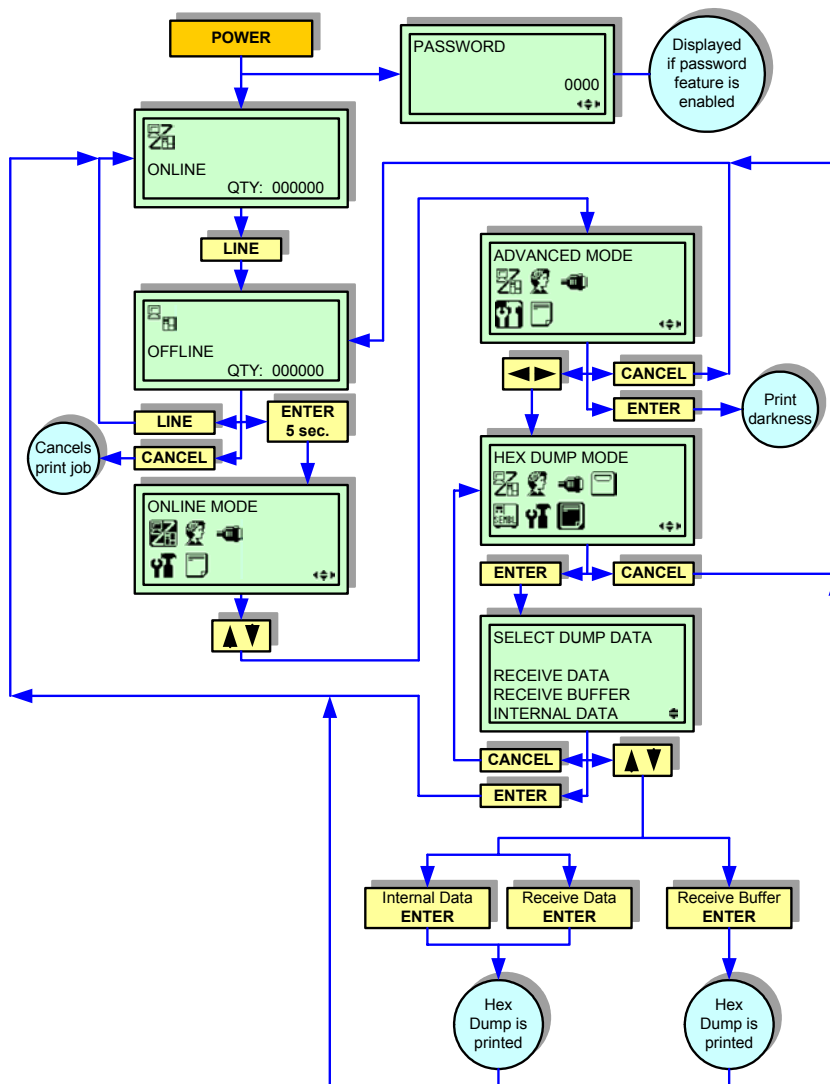

Figure 5-3, Hex Dump Mode

TEST LABEL PRINTING

The test label is designed to assist in the identification of print problems. Follow the flow chart provided below to perform this activity.

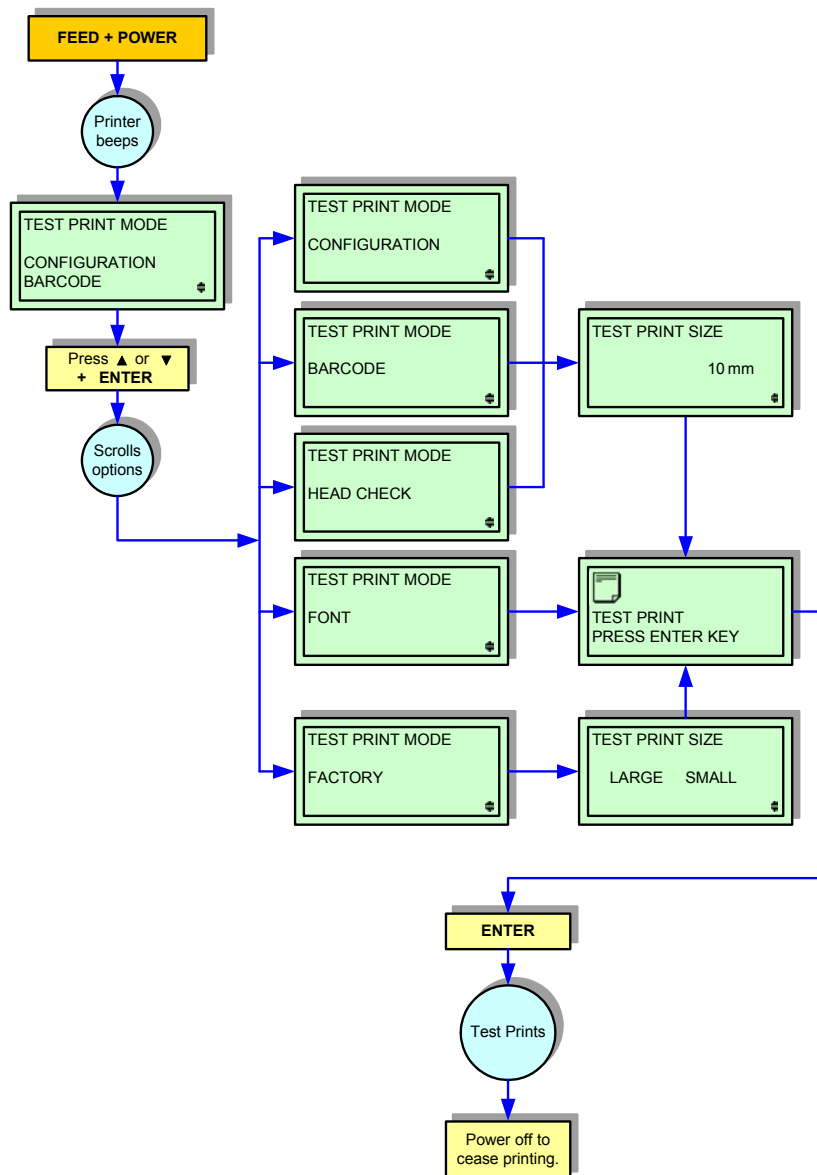

Figure 5-4, Test Print Mode

NOTE: The only print problem that the following sample test label does not display is fading of print image from one side of the label to the other. This is the result of improper print head balance.

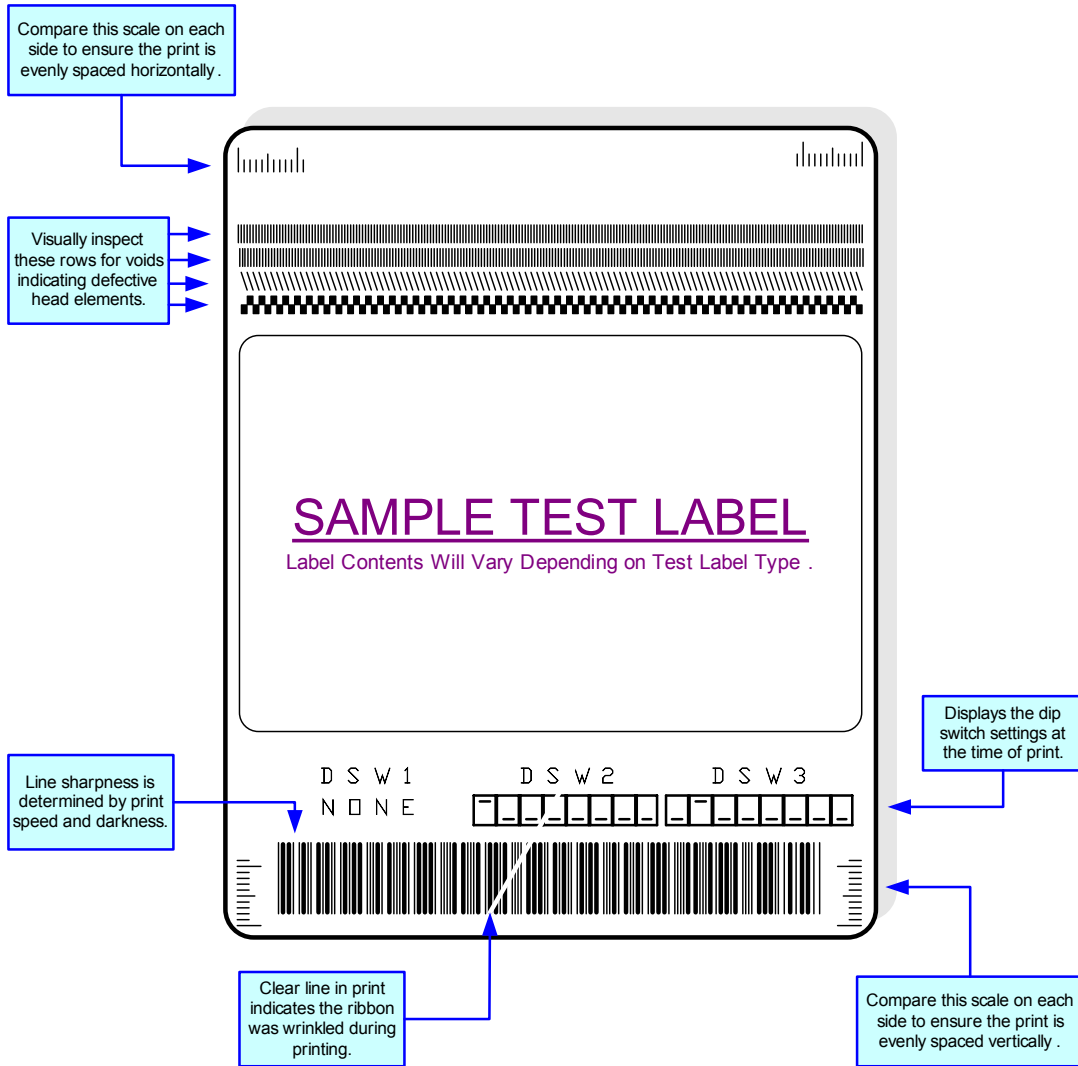

Figure 5-5, Sample Test Label

6

MAINTENANCE

- **Cleaning Procedures**
- **Replacement Procedures**
- **Adjustment Procedures**

CLEANING PROCEDURES

Cleaning of the printer is a necessary maintenance activity to ensure print quality and longer printer life. There are two basic types of cleaning involved; the removal of loose debris and the removal of residue.

Use a soft cloth and/or a pneumatic blower to remove debris from the printer. This process should be performed prior to the removal of residue. To remove residue, apply SATO Solvent or isopropyl alcohol to a clean cotton swab and gently wipe the entire surface of the print head and rollers until clean.

To gain access to the printer's chassis, pull purple knob (1) outward to drop plate (2) downward. Remove thumb-screw (3) should removal of the plate become necessary.

WARNING: DISCONNECT POWER SUPPLY TO THE PRINTER AND ALLOW TO COOL TO ROOM TEMPERATURE PRIOR TO CLEANING. EXERCISE CARE WHEN CLEANING TO PREVENT PERSONAL INJURY.

CAUTION: IF USING A PNEUMATIC BLOWER TO REMOVE DEBRIS FROM THE PRINTER, EXERCISE CARE TO PREVENT PRINT HEAD DAMAGE.

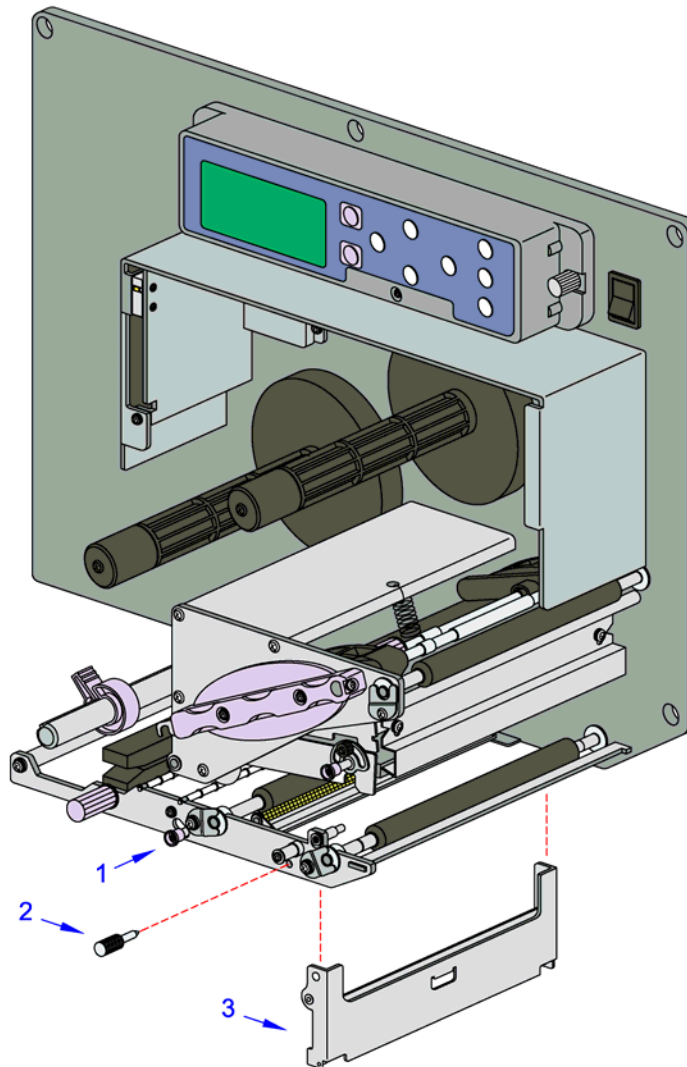

Figure 6-1, Printer Cleaning

REPLACEMENT PROCEDURES

This unit provides in-depth instruction on all primary component and assembly replacement, in addition to most secondary components. Use the text in conjunction with their accompanied graphics to ensure complete comprehension throughout the process. Especially observe all cautionary or warning notations.

FUSE REPLACEMENT

Fuse access may be gained externally without having to remove covers, etc. The fuse is located on the printer's underside adjacent to the power supply cord connector. To inspect or replace the fuse, simply twist off the cap and the fuse will exist with it.

PRINT HEAD REPLACEMENT

If the print head becomes damaged or worn, it can be easily removed and replaced without having to make critical adjustments. Before replacing the print head, check the head counter values by printing a test pattern. Instructions relating to the Head Counter may be found in the Configuration unit of this manual.

1. Switch off the printer and observe applicable lockout-tagout procedures.
2. Open the front cover and the print head release lever.
3. Pull outward on print head release knob (1, Figure 6-2) to release defective print head (2) from print assembly (3). Disconnect the two wiring harnesses.
4. Reconnect two wiring harnesses (not shown) to replacement print head (2).

NOTE: Each of the printer's wiring harness connectors are different from all others to ensure proper mating. Mate each matching half for reconnection.

5. Pull and hold outward on release knob (1) while applying replacement print head (2) to print assembly (3).

CAUTION: THE BRACKETS ON EACH END OF THE PRINT HEAD MUST SNAP INTO POSITION ON THE RELEASE KNOB'S SHAFT. ENSURE THE PRINT HEAD IS SECURELY AND PROPERLY INSTALLED PRIOR TO OPERATING THE PRINTER TO PREVENT MECHANICAL DAMAGE.

6. Restore power, reset the head counter, and test print.

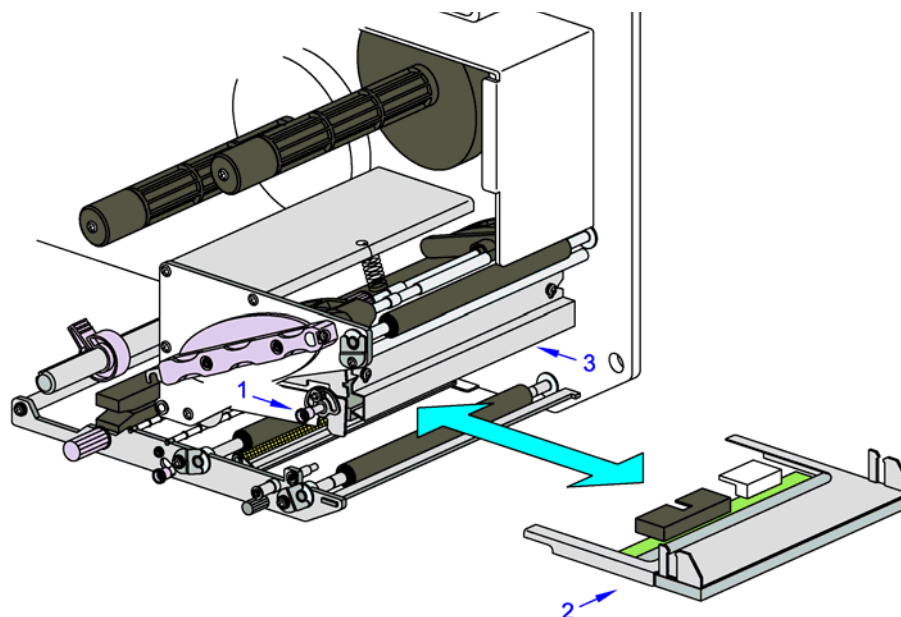

Figure 6-2, Print Head Replacement

ROLLER REPLACEMENT

The printer's three rubber rollers are considered to be high-wear components due to constant treading of the print media and ribbon stock against their contact surfaces. This constant contact will eventually wear grooves into the rubber material and negatively effect print output.

The procedure below applies for all three rubber rollers. However, some rollers do not incorporate the use of spacer (5) so in those cases, that process is to be ignored.

1. Switch off the printer and observe appropriate lockout-tagout procedures.
2. Loosen screw (1, Figure 6-3) sufficiently to rotate bearing clamp (2) from bearing (3).

NOTE: Figure 6-** shows screw (1) and bearing clamp (2) as being removed for display purposes only. It is not necessary to remove those components for roller replacment.

3. Withdraw bearing (3) from chassis (4) and spacer (5) from defective roller (6) consecutively.

NOTE: Ignore removal of spacer (5) if that component is not present on the roller being replaced.

4. Withdraw defective roller (6) from chassis (4) and insert replacement roller (6) in its place.

NOTE: To remove the roller, move it toward its free end and then lift upward.

5. Insert spacer (5) onto the free end of replacement roller (6) followed by bearing (3).
6. Rotate bearing clamp (2) onto bearing (3) and secure using screw (1).
7. Repeat steps 2 through 6 for all other roller assemblies that require replacement.
8. Restore power and test print.

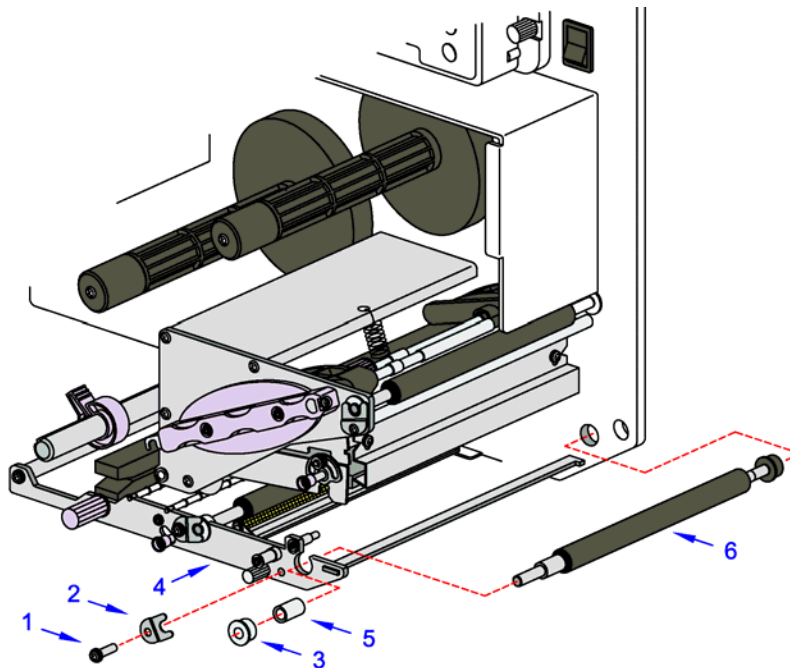

Figure 6-3, Roller Replacement

ADJUSTMENT PROCEDURES

This unit covers all of the printer and printer accessory adjustments. These adjustments include mechanical adjustments required following the replacement of components and assemblies, in addition to, the operational adjustments required following a job change.

PRINT HEAD ALIGNMENT

Print head position has a direct impact on print quality. The print head must be parallel with the platen roller for the printed image to be consistent across the label.

To adjust the alignment, test print a label, loosen the set screw, slightly move the adjustment plate to the right or left as deemed necessary to align the print head with the roller, and reprint a label. Repeat the process until proper printing is achieved and then retighten the set screw while holding the adjustment plate in position.

CAUTION: THE PURPLE KNOB HASN'T ANYTHING TO DO WITH PRINT HEAD ALIGNMENT. PULLING ON THIS KNOB WILL RELEASE THE PRINT HEAD.

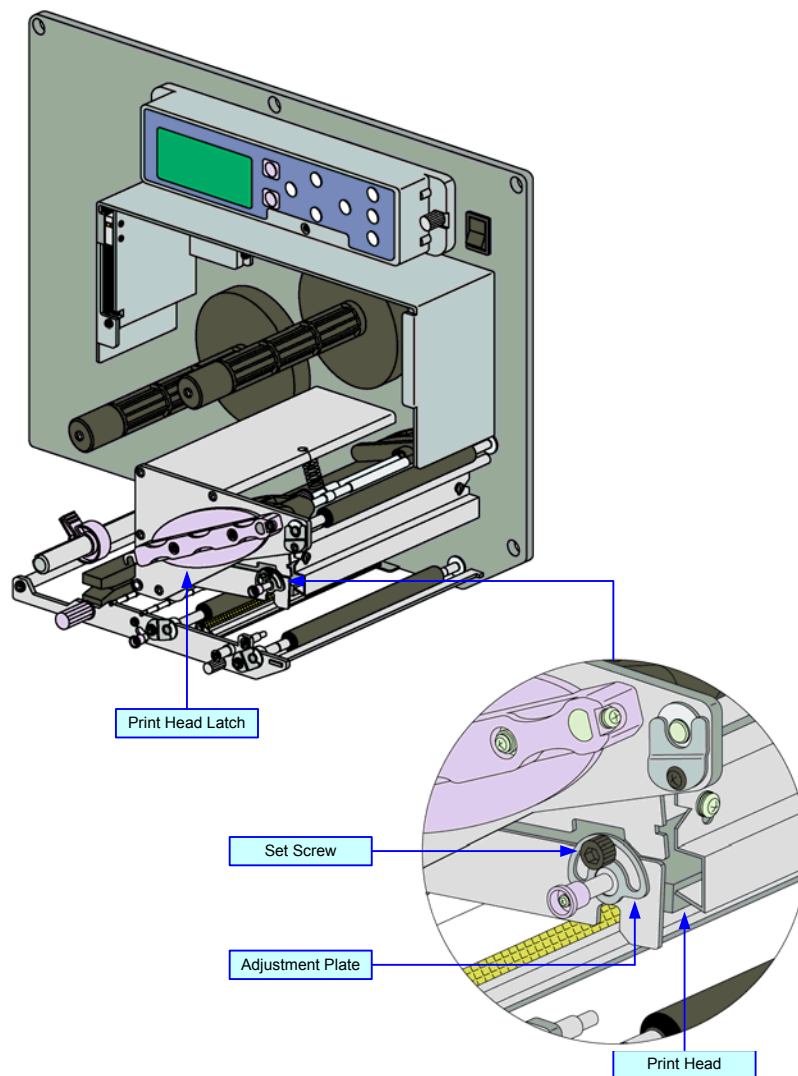

Figure 6-4, Print Head Alignment

PRINT HEAD PRESSURE ADJUSTMENT

Print head pressure adjustment allows for the print head to be adjusted to accommodate different media types (thicknesses). The pressure setting switch is two position (normal, high). The table that follows correlates the media used with a pressure setting.

PRESSURE/BALANCE ADJUSTMENT				
Paper Width (inches)	2.17+	0.612 to 2.16	2.56+	0.62 to 2.55
Dial Setting	1	2	3	4

PRESSURE REQUIREMENTS		
Paper Thickness (inches)	0.003 to 0.008	0.008 to 0.010
Dial Setting	1 or 3	2 or 4
Reference	Thin paper/normal label, etc.	Thick paper/tag, etc.

NOTE: The dial is innumerated on the side to assist in position selection. The bottom most numeral represents the setting.

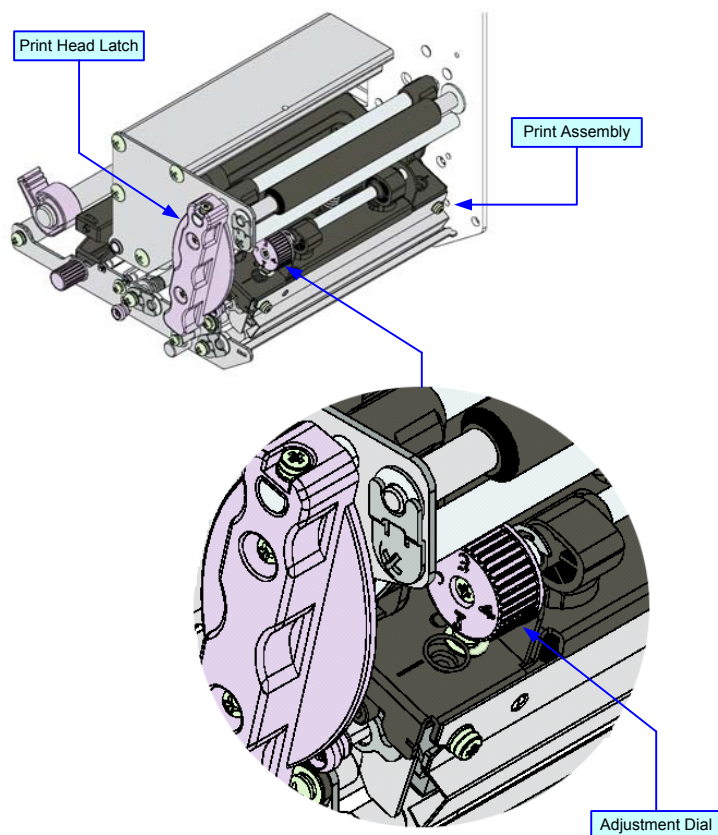

Figure 6-5, Print Head Pressure Adjustment

PRINT HEAD BALANCE ADJUSTMENT

Print head balance is the equalization of pressure against the platen roller from one end to the other. If the print head balance is out of adjustment, the printed image will be darker on one side of the label than the other and the media will be prone to travel in the direction of least resistance.

The adjustment of print head balance on the label can be subjective. One will know when balance is achieved by the disappearance of prevailing negative print characteristics.

To adjust the balance, begin test printing, slightly loosen the set screw, and slightly move the adjustment plate to the right or left as necessary. Retighten the set screw while holding the adjustment plate when proper printing is achieved.

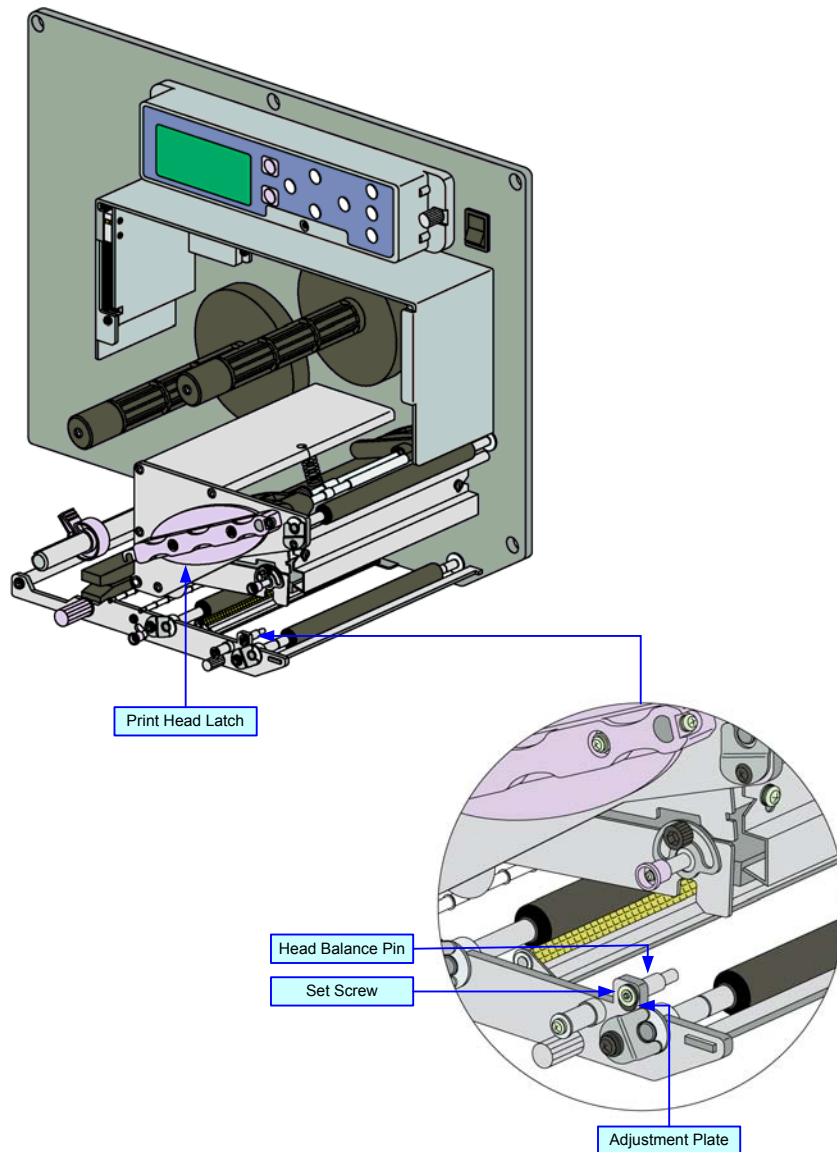

Figure 6-6, Print Head Balance Adjustment

RIBBON GUIDE ADJUSTMENT

If the print ribbon is not spread smoothly over the print head when it makes contact with the media, print voids will occur at the point of the ribbon fold. Typically, this is the result of the axis of one of the following not being perfectly parallel: ribbon spindle, ribbon roller, print head, or ribbon guide.

The purpose of the adjustable ribbon guide is to compensate for the axis deviations of the other three. By adjusting the ribbon guide proportionally to the degree of deviation, the ribbon spreads smoothly as it travels from the ribbon supply spindle, to the guide, and beyond.

Ribbon guide adjustment is a trial and error activity that requires the pause of printing, unlatching of the print head, adjusting the guide, relatching the print head, and printing once again. Several labels must be printed following each adjustment to determine if the adjustment was effective.

The ribbon guide is secured to the face of the print assembly by a screw on each end. Before adjusting the guide, visually inspect that its axis is parallel with that of the print assembly. If not, adjust accordingly, ensure the set screws are secure, and once again commence printing.

By starting in a neutral position, either end may be adjusted vertically as necessary to remedy the wrinkling problem.

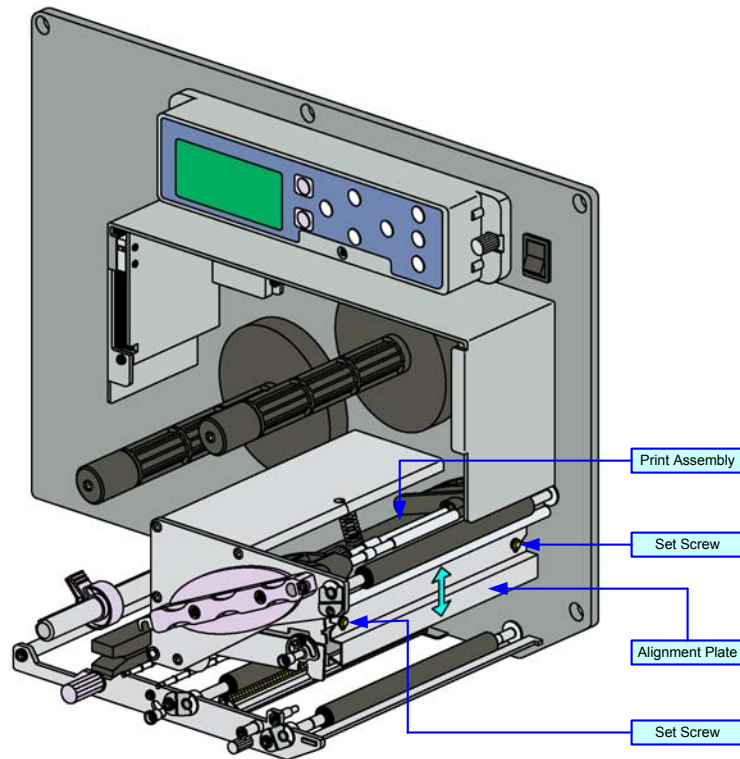

Figure 6-7, Ribbon Guide Adjustment

LABEL SENSOR POSITIONING

The label sensor assembly provides a mounting apparatus for the eye-mark, gap, and paper-end sensors. Position adjustment of the label sensor is not required when using standard label media.

When non-standard media is used, place a section of the media on the media ramp oriented as if loaded for printing. Manually grasp the sensor assembly and move it laterally so that the sensor indicators embossed in its side are aligned with the reference marks on the media.

Sensor positioning may also be achieved by measuring from the printer's center frame outward to a specified distance for sensor/reference mark alignment.

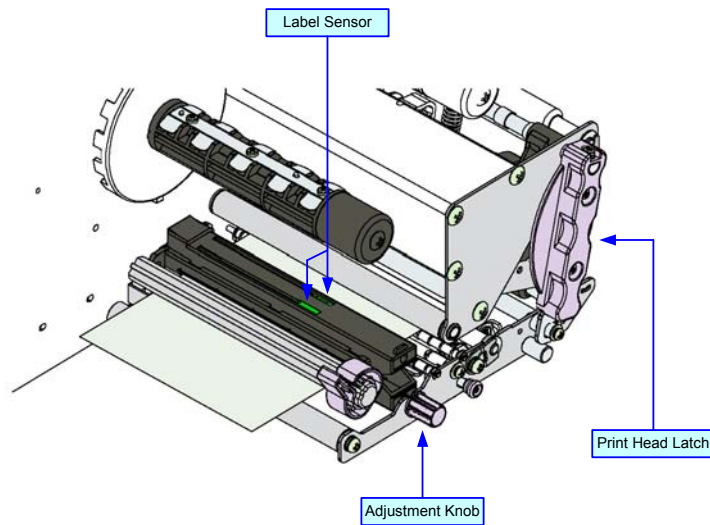

Figure 6-8, Label Sensor Positioning

OPERATIONAL ADJUSTMENTS

These operational adjustments are for fine tuning the printer as necessary following the configuration process and are largely confined to the four potentiometers located on the operator panel. Refer to the table below for their function.

POTENTIOMETER	DESCRIPTION/PROCEDURE
VOLUME	Adjusts the audible decimal level for error indication. Power on the printer, place on-line, and open the print head. When the beep is emitted, adjust the volume level accordingly.
PITCH	Is to be used in conjunction with the configuration adjustments. Make course adjustments there and then fine tune here. If unable to achieve the desired setting here, the course adjustment must be reset. Adjust this potentiometer as labels are being printed. Allow two labels to be printed for each adjustment to ensure a desired setting. Adjustment of the PITCH potentiometer will affect the print offset position.
OFFSET	The offset adjustment is used to reposition the media for printing following advancement for dispensing. A label is printed, it is fed forward for dispense, the printer retracts the remaining media (offset) to print the next label. To perform this adjustment: <ol style="list-style-type: none"> 1. Power On the printer. 2. Press the LINE key to place printer offline. 3. Advance to the User Mode and press ENTER. 4. Adjust the OFFSET potentiometer. 5. Press the FEED key to feed another label. 6. Repeat steps 3 and 4 until properly adjusted. 7. Press the LINE key to bring the printer back online.
DARKNESS	Is used to adjust the darkness or lightness of the printed image and should be used in conjunction with the configuration adjustments. Make course adjustments there and then fine tune here. If unable to achieve the desired setting here, the course adjustment must be reset. Adjust this potentiometer as labels are being printed. Allow two labels to be printed for each adjustment to ensure a desired setting.

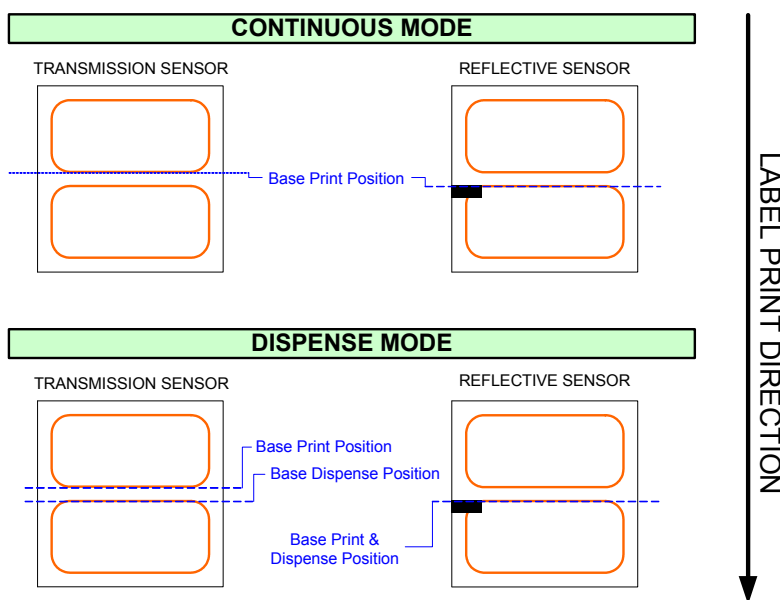

Figure 6-9, Print Base Reference Position

7

APPENDIX

- **Session Connect/Disconnect Diagram**
- **Ready/Busy Timing Charts**
- **X-On/X-Off Timing Charts**
- **Printer Dimensions**
- **Glossary**

SESSION CONNECT/DISCONNECT DIAGRAM

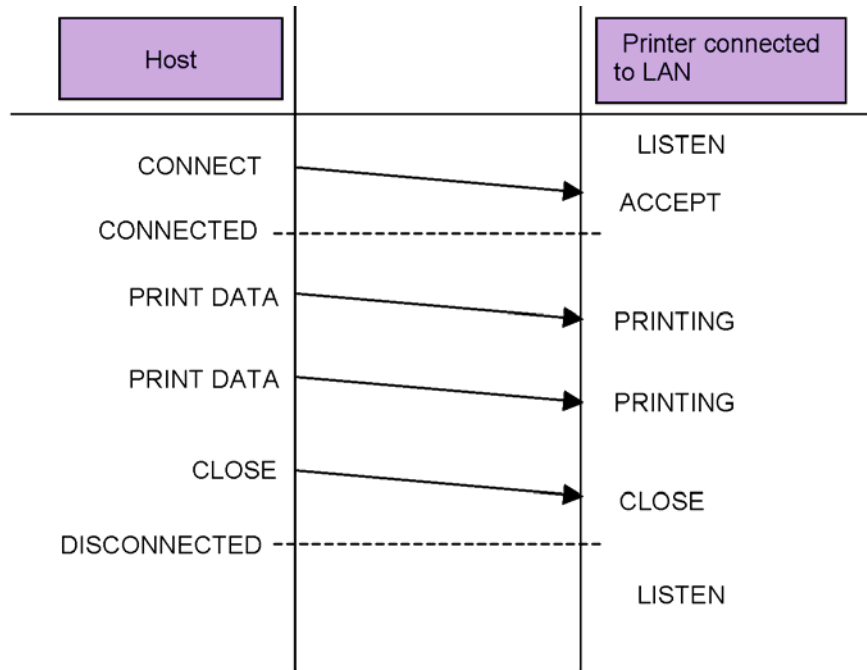

2) Port1025 for status return

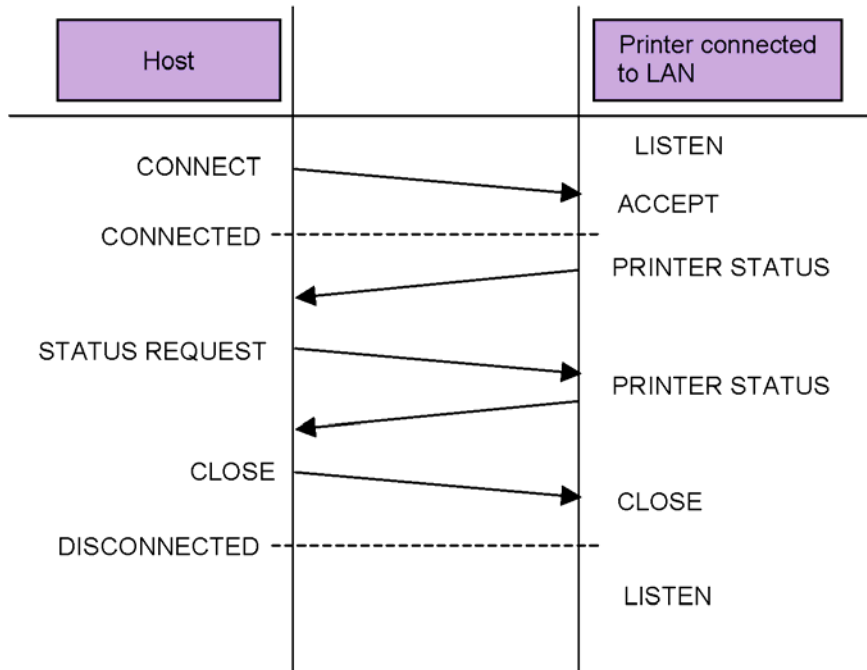
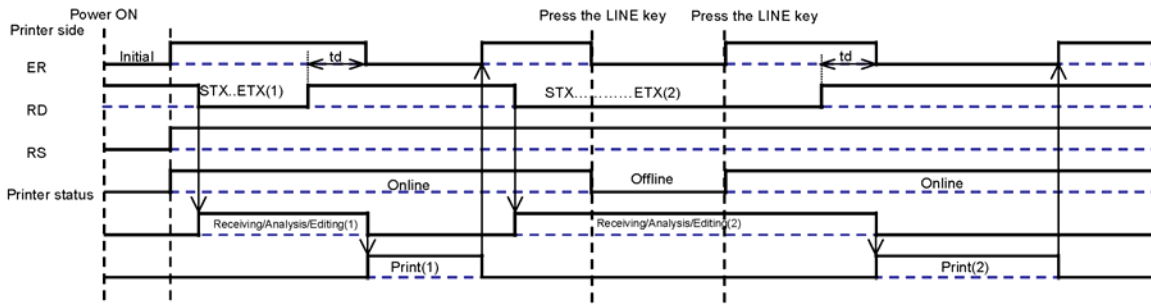

Figure 7-1, Session Connect/Disconnect Diagram

READY/BUSY TIMING CHARTS

1) Normal process



td It takes the printer 10µs approx to recognize the end of item and to start controlling ER.

2) Error process

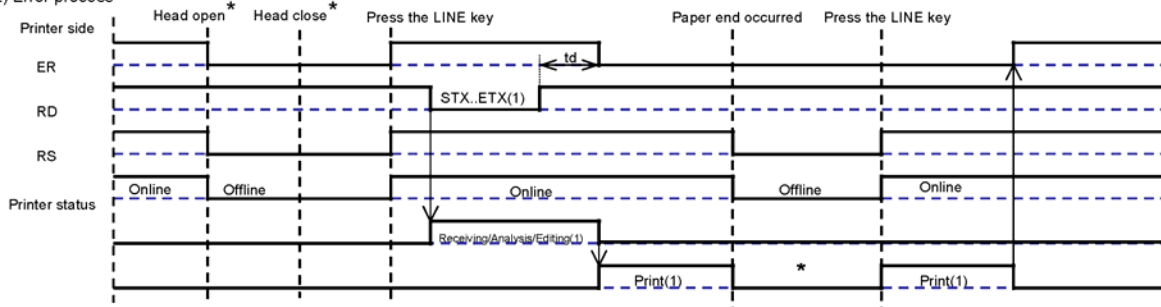
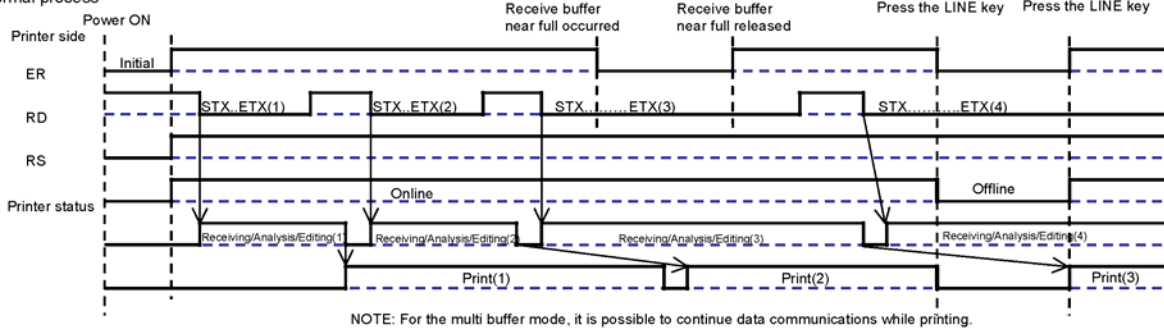

Figure 7-2a, Single-Item Buffer Timing Charts

1) Normal process



NOTE: For the multi buffer mode, it is possible to continue data communications while printing.

2) Error process

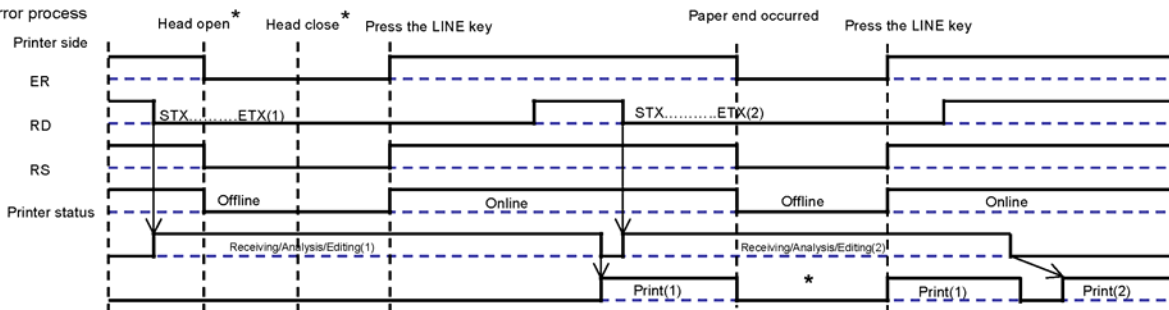
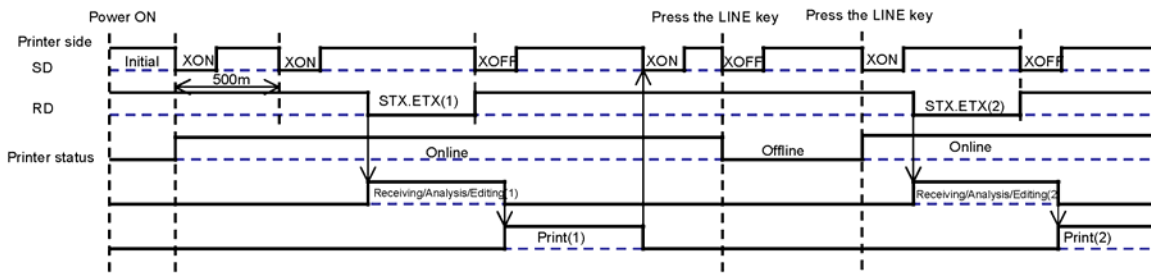

Figure 7-2b, Multiple-Item Buffer Timing Charts

X-ON/X-OFF TIMING CHARTS

(1) Normal process



NOTE: In this protocol, executing the polling of "XON" at intervals of 500ms from the power supply to the first data reception.

(2) Error process

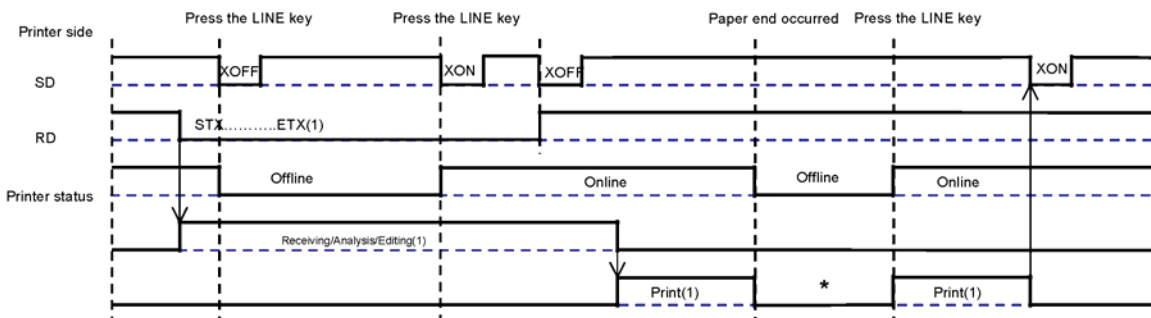
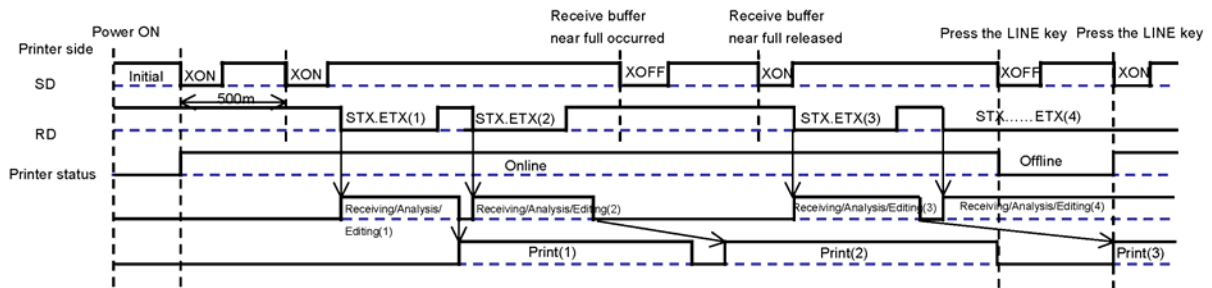

Figure 7-3a, Single-Item Buffer Timing Charts

(1) Normal process



NOTE: In this protocol, executing the polling of "XON" at intervals of 500ms from the power supply to the first data reception.

(2) Error process

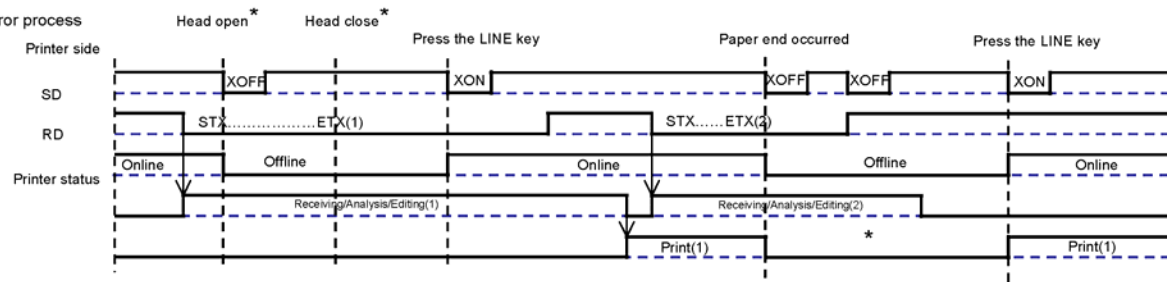

Figure 7-3b, Multiple-Item Buffer Timing Charts

PRINTER DIMENSIONS

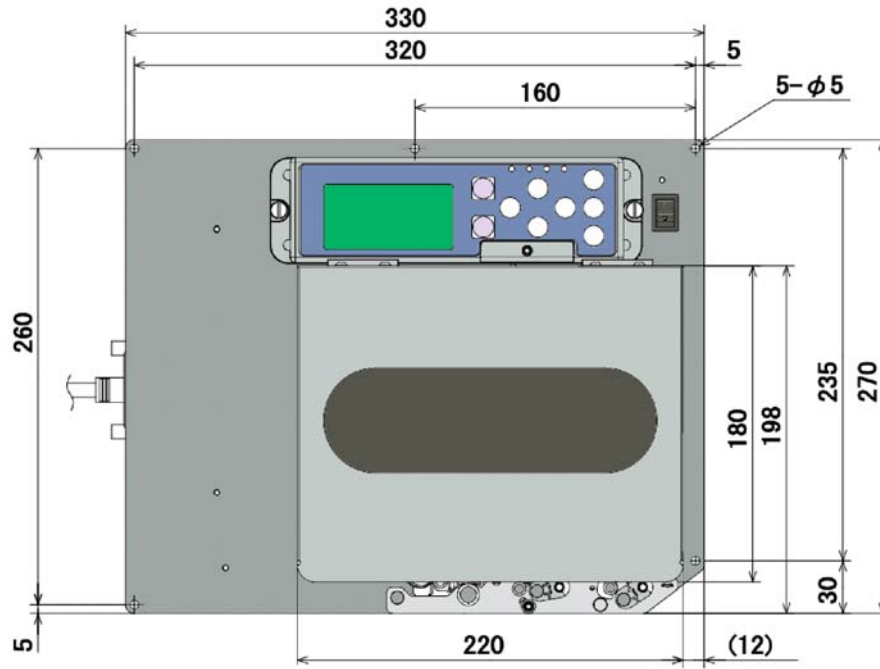

Figure 7-4a, Front View

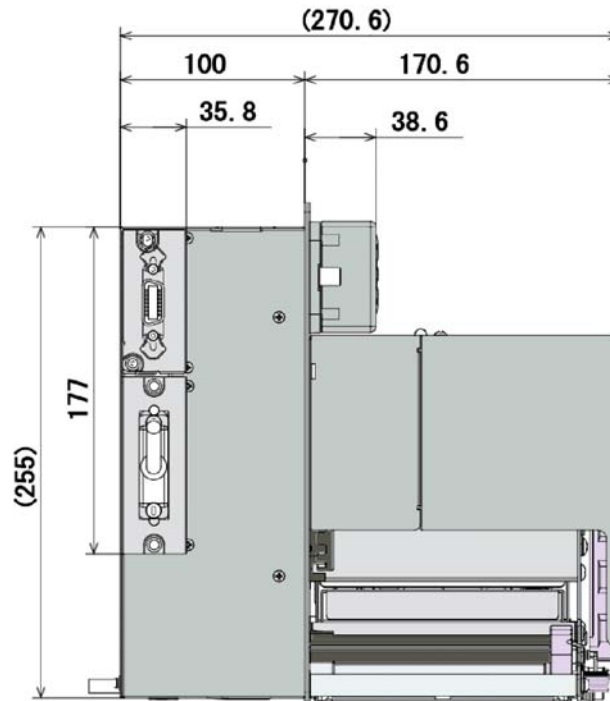

Figure 7-4b, Interface Side

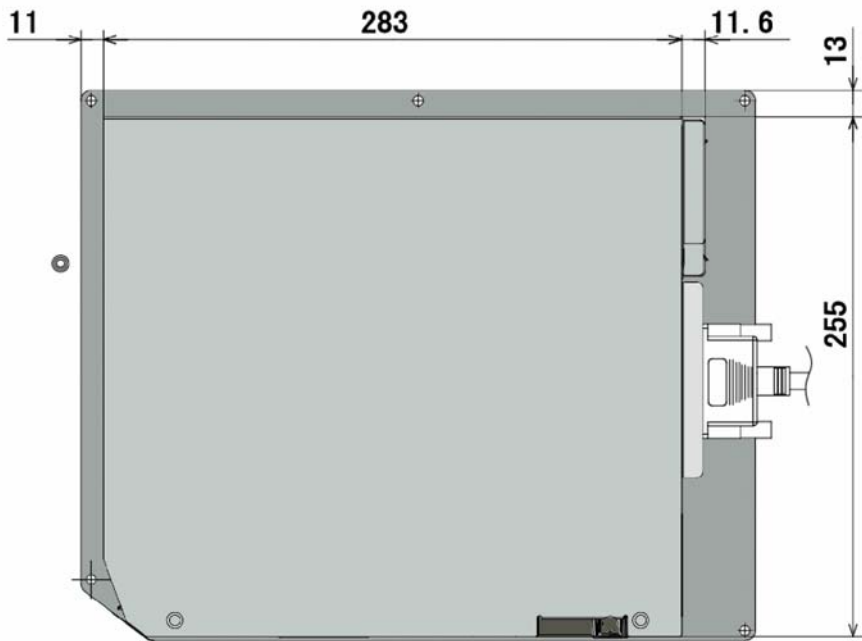

Figure7-4c, Back View

GLOSSARY

GLOSSARY	
AC	(Alternating Current) Electrical current that reverses its direction regularly and continually.
Accessory	An optional assembly that may be used to provide an additional function.
Active Tags	RFID tags which use batteries as partial or complete source of power which are further differentiated by separating them into those with replaceable batteries and those which have the batteries inside a sealed unit. Also referred to as Utilized Active Tags.
Addressability	The ability to address bits, fields, files, or other portions of the storage in an RFID tag.
Advance	To bring forward - the opposite of retract.
Allen Screw	A screw whose head has a hexagonal recess to be driven by an allen wrench.
Aluminum	A silvery, light-weight, metal that resists corrosion.
Anti-Static	Resists static electricity.
Arc	A bow-like curved line or object.
	The band of sparks between to closely placed electrodes when current leaps the gap from one to the other.
ASCII	(American Standard Code for Information Interchange) The most common format for text files in computers and on the internet. In a ASCII file, each alphabetic, numeric, or special character is represented with a 7-bit binary number (a string of seven 0s or 1s). 128 possible characters are defined.
Assembly	The fitting together of parts, components, or sub-assemblies to form a complete unit.
Asynchronous	A type of two-way communication that occurs with a time delay, allowing participants to respond at their own convenience. This communication allows characters to be sent at irregular intervals by preceding each character with a start bit and following it with a stop bit. The timing of the transmission is not determined by the timing of the previous character.
Audible	A sound loud enough to be heard.
Batch	A grouping of anything.
Baud	<p>The number of signaling elements that occur each second; or stated differently, the number of changes to the transmission media per second in a modulated signal.</p> <p>At slow speeds, one bit of information (signaling element) is encoded in each electrical change. The baud therefore, indicates the number of bits per second (bps) that are transmitted.</p> <p>Assuming asynchronous communication, which requires 10 bits per character, this translates to 30 characters per second (cps). For slow rates, (below 1200 baud), the baud can be divided by 10 to see how many characters per second are sent.</p> <p>At higher speeds, it is possible to encode more than 1 bit in each electrical change. Thusly, 4800 baud may allow 9600 bits to be sent each second.</p> <p>At high data transfer speeds, data transmission rates are usually expressed in bits per second (bps) rather than baud.</p>
Bi-Directional	Capable of operating in two directions along the same plane or medium. In the case a communication cable or an RFID tag, one that transmits as well as receives, read and written.
Binary	A numeral system that represents numeric values using two symbols, typically 0 and 1. A binary number can be represented by any sequence of bits (binary digits), which in turn may be represented by any mechanism capable of being in two mutually exclusive states.
Bits	Refers to a single digit in the binary numeral system. A bit can either be <i>on</i> or <i>off</i> - a 1 or 0. A byte is a collection of eight bits.
Block Diagram	Shows the interconnections between system components by using a pictorial representation of a system and sub-systems linked to illustrate their relationships.
Bolt	A threaded metal rod with a flanged head that is used with a nut to hold parts together.
Bore	A hole in, or through something.

GLOSSARY	
Bytes	A collection of 8 bits used in the binary system.
Capacity	As it relates to RFID, the number of bits or bytes that can be programmed into a tag. This may represent the bits accessible to the user or the total number - including those reserved to the manufacturer (e.g., parity or control bits).
Capture Window/Field	Region of the scanner field in which an RFID tag will operate.
Cavity	A recessed area in something. In the case of a die set, the core is one of two part with the core being its mating half.
Chamfer	To slice off the corners of an angle to create a beveled edge.
Character	Any single numeral, letter, or symbol.
Chassis Assembly	A group of components or sub-assemblies that comprise the base of an assembly.
Circumference	The periphery of a circle or other rounded object - also the measurement of this distance.
Circuit	A network of wires, resistors, and other electronic devices over which electrical impulses travel.
Clockwise	To rotate from left to right.
Closed Systems	As it relates to RFID, a system in which relevant data regarding the attributes of the object is stored in a common database accessible via data link by referencing the individual ID code.
Collar	A sleeve applied to a rod, shaft, or pipe to prevent sideward motion.
Component	A single part that may applied to others to form an assembly.
Composite	An object that is comprised of, or layered with, two or more materials to achieve a desired outcome.
Concave	A curved recess or hollow - the opposite of convex.
Concentric	Multiple items that share a common center - example: a circle centered within a circle.
Configuration	The arrangement of parts or components to operate in unison for a specific activity.
	To program software to enable, disable, or specify how various features will function.
Connector	Devices for joining electrical and electronic circuits through coupling. Typically, one mating half is a plug (male) and the other is a socket (female).
Convex	A spherical shaped surface - one that is curved outward.
Core	The protruding portion of a die set. The core is one of two parts and the cavity being its mating half. The core is convexed and the cavity is concaved.
CPU	(Central Processing Unit) A programmable device that performs all the instruction, logic, and mathematical processing in a computer - is the brains of the computer. The CPU is a microchip that is installed on a motherboard (primary board) that coordinates hardware components. Also referred to as "processor".
Counter-Clockwise	To rotate from right to left.
Couple	Two mating halves that are connected - example: a plug or receptacle.
Cubic	The X, Y, and Z axis all being equal in size - a three-dimensional object that is equally proportioned.
Current	The flow or rate of flow of electric force.
Cycle	A single revolution of a potentially reoccurring activity - in the case of printer, one label being printed.
DC	(Direct Current) Electrical current flowing in a single direction.
Density	The quantity within a given or specific area or unit.
Deviation	A change in course or the measurement of that change.
Diameter	A straight line from the outer edge of a circle, through the center, and onward to the opposite edge. Also the measurement of that distance (dimension).
Dimension	Any measurable distance.

GLOSSARY	
Diode	Allows current to flow in one direction but not the other to protect sensitive electronics. A diode functions by compositing two conductive materials with one possessing low resistance to electrical current on one side and high resistance on the other.
Dipswitch Complex	A group of tiny switches directly attached to a circuit board to enable configuration for a particular type of application. These switches are two-position: On/Off.
Direct Thermal	The printing method that uses a chemically coated heat sensitive media. Once the heat from the thermal printhead is applied to the media, the media darkens with the image. Direct thermal printing does not require ribbon and is typically used in applications where the label needs to endure for a year or less.
Disable	To deactivate or make unable to function.
Divergent	To deviate from the norm or to possess opposing positions.
DPI	(Dots Per Inch) The quantity of printed dots within a square inch area - the print density.
DRAM	(Dynamic Random Access Memory) DRAM is the most common kind of RAM and is a network of electrically-charged points in which a computer stores quickly accessible data in the form of 0s and 1s. Each storage or memory cell can be directly accessed if the intersecting row or column is known. Each cell consists of a capacitor and a transistor.
Drive Train	The components and sub-assemblies that comprise the mechanical apparatus of motion or kinetic energy.
Eccentric	Multiple items that do not share the same center - example: a circle whose center axis is not the same as that of another to whom it is connected. The opposite of concentric.
E-Clip	Type E snap ring.
EEPROM	(Electrically Erasable Programmable Read-Only Memory) Are ROM chips that do not have to be removed to be rewritten. Nor does the entire chip have to be completely erased to change a specific portion. Changing the contents does not require additional dedicated equipment. The localized application of an electric field to each cell erases the targeted cells which can be rewritten. Since only 1 byte can be changed at a time, EEPROM's are versatile but slow.
Electronic Label	A label that has an electronic RFID tag embedded within.
Electromagnetic Coupling	In RFID, a system that uses a magnetic field as means of transferring data or power.
Electrostatic Coupling	In RFID, a system which uses the induction of voltage on a plate as a means of transferring data or power.
Ellipse	An oval shape that is symmetrical on either side of its center when divided into quadrants.
Embossed	Characters or graphics that are raised above the remaining surface.
Enable	To activate or make able to function.
Encompass	To surround, encircle, or contain.
Error Correcting Code	(ECC) In RFID, supplemental bits in a data transfer used in conjunction with a polynomial algorithm in order to compute the value of missing or erroneous data bits. Example: for a 32-bit data transmission, seven additional bits are required.
Error Correcting Mode	Relative to RFID, a mode of data communication in which missing or erroneous bits are automatically corrected.
Error Correcting Protocol	Relative to RFID, the rules by which the error-correcting mode operates.
Error Management	In RFID, the techniques used to ensure that only correct information is presented to the system's user.
Error Rate	In RFID, the number of errors per number of transactions.
Exciter	In RFID, the electronics which drive an antenna. When coupled with antenna, they are collectively referred to as a scanner. Also referred to as a transmitter.
Expansion Port	A plug accessing additional I/O capability on a computer or peripheral device.
Eye-Mark Media	Print media with a mark on the paper backing between each label for the label sensor to read. This mark is used by the printer to identify the end of the printed label so that the next up can be properly positioned for printing.

GLOSSARY	
Factory Programming	Relative to RFID, the programming of information into a tag occurring as part of the manufacturing process resulting in a read-only tag.
Field Programming	In RFID, programming that usually occurs before the tag is installed on the object to be identified enabling the introduction of data relevant to the specifics of the application. However, the tag would typically have to be removed from its object.
Field Protection	In RFID, the ability to limit the operations that can be performed on portions of data fields stored in a tag.
Fillet	To round off the sharp edges of the angle.
Flange	The projecting rim of an object used to keep another object or objects in place.
Flash Memory	A form of rewritable memory chip that allows multiple memory locations to be erased or written in one programming operation. Flash Memory is very high-speed and non-volatile - does not need power to maintain the stored information. Its information is stored in an array of floating gate transistors called "cells".
Font	A type or style of letter or numeral characters used in written text.
Frequency	The number of times a signal executes a complete excursion through its maximum and minimum values and returns to the same value. The number of vibration cycles.
Gap Media	Print media with a space between each label where only the paper backing exists. The printer's sensor uses this "gap" to identify when the printed label ends and to properly position the next label for printing.
Gauge	A unit of measurement used to describe the nominal thickness of wire. The higher the gauge number, the smaller the diameter.
Gear	A system of toothed wheels meshed together so that the motion of one is passed on to the others.
Gigabytes	Used to describe data transfer rates or storage capacity of 1 billion bytes.
Groove	An elongated slot cut into an object.
Hertz	Radio waves or other electromagnetic radiation resulting from oscillations of electricity in a conductor. Also the measurement of those oscillations.
Hexidecimal	A numbering system composed of six letters (A-F) and ten numbers (0-9) used to condense binary numbers.
Hex Screw	A threaded rod having a flanged head that is comprised of six sides - a type of hardware used to attach two or more objects.
Hole	In engineering: a recess that does not penetrate completely through as a bore or orifice. Term may be casually used in lieu of a bore or orifice.
Horizontal	On a level plane ninety-degrees from vertical.
Hz	(Hertz) Radio waves or other electromagnetic radiation resulting from oscillations of electricity in a conductor. Also the measurement of those oscillations.
Icon	An image or picture that has a specific meaning.
I.D. Filter	In RFID, software that compares a newly read ID with those in a database or set.
Idle Gear	A toothed wheel that is not directly driven, but instead receives motion from another.
Idle Roller	A non-toothed wheel that is not driven - in the case of printers, it is typically used to provide tension on a timing belt. Also referred to as "tension roller".
Illuminate	To give or emit light.
Inductive Coupling	In RFID, systems that use the inducing of a current in a coil as a means of transferring data or power.
Intermittent	Stopping and starting again at intervals.
In-Use Programming	The ability to read from, and write to, an RFID tag while attached to its object.
Junction	A place or point of joining or crossing.
Kinetic	The science dealing with the motion of masses in relation to the forces acting on them.

GLOSSARY	
Key	The button on a panel that may be pressed to send an electrical signal to influence a predetermined activity.
Keyed	A physical object shaped in a manner so as to prevent unwanted movement or to ensure desired movement.
Kg	(Kilogram) A unit of weight measure within the metric system.
Kilo-Bytes	Used to describe data transfer rates or storage capacity of approximately 1000 bytes.
Knob	A rounded handle to facilitate the manual opening, closing, securing, or otherwise movement of the object to which it is attached.
Knurled	An item that has recessed grooves or elevated areas on its surface to increase manual grip.
Label	Print media that has been used or printed upon that has adhesive on one side.
LAN Interface	(Local Area Network) A computer network limited to the immediate area, consequently capable of transmitting data at a very fast rate. Usually the computer is limited to the same building, or floor of a building, as the periphery device.
Latch	An object that is designed to be moved from one position to another for the purpose of preventing or allowing the opening of another object.
Lateral	Movement to the left or to the right - horizontal movement.
LCD	(Liquid Crystal Display) A display technology involving optical glass panels whose opacity can be controlled by electrical signals. A liquid crystal surface is sandwiched between two polarizing panels and when voltage is applied to certain areas, the crystal darkens. A light source behind the panel transmits through the transparent crystals and is mostly blocked by the darkened ones.
LED	(Light Emitting Diode) A semiconductor light source that emits visible light or invisible infrared radiation. The color of the emitted light depends on the chemical composition of the semiconducting material used.
Lever	An object that turns on a fixed point usually to engage or disengage a latch.
Laminate	A film or sheet placed onto and adhered flatly over another material.
Life	Relative to RFID, the functional period within which maintenance, adjustment, and repair is not reasonably expected.
Linear	The measurement of length without consideration of other dimensions.
Linerless Media	Print media that does not have a space between each label as does the eye-mark and gap type media. This media is continuous and is divided based on printer programming.
Link	An active connection to another document, graphic, or address. By selecting the designated button, text, graphic, or screen location; one is taken to the predetermined linked location.
M	(Meter) A unit of measure in the metric system equal to 39.37 inches.
MB	(Megabytes) Used to describe data transfer rates or storage capacity of approximately 1 million bytes depending on the manner of compression.
MM	(Millimeter) A unit of measure in the metric system equal to 0.03937 (1/25) inches.
Media	In printing, a batch of unprinted labels or tags.
Megabytes	Used to describe data transfer rates or storage capacity of approximately 1 million bytes depending on the manner of compression.
Menu	A display of items that may be chosen.
Meter	A unit of measure in the metric system equal to 39.37 inches.
Millimeter	A unit of measure in the metric system equal to 0.03937 (1/25) inches.
Module	A self-contained unit that may be plugged into another unit to operate.
Multimeter	A device that is used to measure output units relating to electrical current.
Memory Card	Relative to RFID, a read/write or reprogrammable tag in credit card size.
Memory Modules	A read/write or reprogrammable RFID tag.
Mobile Inventory Vehicle	In RFID, a vehicle equipped with a system for locating tagged vehicles, containers, and other objects for the purpose of inventory control.

GLOSSARY	
Modulation	In RFID, the methods of altering carriers in order to transmit the encoded information.
Nest	A set of similarly shaped objects with one smaller and resting within the other.
Nominal	The point between a positive and negative deviation which is considered to be optimum.
Nut	A small metal block with a threaded hole through its center for screwing onto a bolt.
Nylon Material	A milky-white, synthetic material used in manufacturing that is purchased in blocks and machined to the desired shape - resembles plastic.
Offset	In label printing, it is the repositioning distance that the printer must make after advancing the printed label for cutting or dispensing. The offset is the distance that the media must be retracted following one of those activities so that printing may again take place.
Omni-Directional	The ability of an RFID tag to operate in any orientation.
Orientation	Having to do with the manner or angle of placement.
Orientation Sensitivity	In RFID, the range or measurement of decreased readability by non-optimal orientation.
Orifice	An opening for which something is to pass through - similar to a bore.
O-Ring	A typically circular object made of round, elastic material to provide a seal between two objects.
Oscillate	To move back and forth along a span.
Pan Head Screw	A threaded rod with a rounded, flanged head used to attach multiple object together.
Paper	In printing applications, the temporary backing for print media. The paper is removed following printing so the label may be applied.
Parallel	Objects extending in the same direction maintaining the same distance part.
Parallel Interface	An interface between computer and printer where the computer sends multiple bits of information to the printer simultaneously by sending each bit over a separate wire.
Parameter	The span or area that something is allowed to exist or operate.
Parity	A simple form of error checking that is used in serial communication. A parity bit is a binary digit that is added to a group of bits to detect the presence of an error. The parity bit take on the value of an 0 or a 1 to satisfy a constraint on the overall parity of a binary number. The parity scheme in use must be specified as even or odd. Parity is even if there are an even number of 1 bits, and odd otherwise. None may also be chosen.
Passive Tags	Passive RFID tags that do not contain an internal power source. They are externally powered and typically derive their power from the carrier signal radiated from the scanner.
PC	(Personal Computer) An electronic computing device that may be individually and independently used or coupled to other similar devices.
Perforation	A series of through-holes in a material to facilitate tearing apart.
Perpendicular	At right angles to a given line or plane - a vertical line is perpendicular to a horizontal one and vise-versa.
Phenolic Material	A black, synthetic material used in manufacturing that is purchased in blocks and machined to the desired shape - resembles plastic.
Pinion Gear	A smaller gear meshed with a larger one.
Pitch	Physical top of form of media placed under the print head elements in the feed direction.
Plastic	A synthetic material typically rigid in nature that is molded to its useful shape. Plastic is typically injection molded along with its color additive and may be of any color chosen.
Post	A pin or shaft to which an object may be tethered or latched.
Potentiometer	A variable resistor used to adjust voltage to affect various mechanical activities. This electronic component is comprised of two terminals connected to either end of an resistive element and a conductor that can be moved between the two ends, thus allowing the creation of a resistor or voltage divider.
Primary	Something first in order or importance.
Print Assembly	The sub-assembly of a printer that comprise the printing components.

GLOSSARY	
Print Head	The device on a direct thermal or thermal transfer printer containing the heating elements that causes an image to be transferred to print media.
Processor	A programmable device that performs all the instruction, logic, and mathematical processing in a computer - is the brains of the computer. The processor is a microchip that is installed on a motherboard (primary board) that coordinates hardware components. Also referred to as "CPU".
Profile	A side view of an item.
Program	To enter or send to the processor, the control parameters for electronic equipment to operate.
Proportional	To be equal.
Proximity Sensor	A device that detects and signals the presence of a selected object at, or near, the sensor's location.
Pulley	A toothed wheel for providing movement to a belt.
Quadrant	One quarter of the circumference of a circle.
Radial	Branching out in equal distances from a common center.
Radius	A straight line from the center of a circle or sphere to its periphery - also the measurement of its distance.
RAM	(Random Access Memory) A network of electrically-charged points in which a computer stores quickly accessible data in the form of 0s and 1s. Each storage or memory cell can be directly accessed if the intersecting row or column is known.
Ratio	The quotient of one quantity divided by another of the same kind.
Reader	Relative to RFID, a device containing the digital electronics which extract and separate the information from the format definition and error management bits.
Read/Write	Relative to RFID, many applications require that new data or revisions to data already in the tag, be entered while it remains on the object. Some items with this capability of being re-programmable are read/write tags, memory cards, or memory modules.
Receive Buffer	An area of temporary data storage to help compensate for differences in the transfer rate and the processing ability of the printer.
Receptacle	A female connector to which a male connector may be inserted - typically for electrical current.
Relay	A simple electro-mechanical switch made up of an electromagnet and a set of contacts. Relays use a small amount of power to energize things that require a greater amount of energy. Sometimes relays are serial connected so that one smaller relay activates a larger relay which in turn, activates another larger still, and so on until the thing that is desired to be activated - is.
Retain	To keep or to hold in place.
Retract	To withdraw - the opposite of advance.
Resistor	A two-terminal electrical or electronic component that resists the flow of current producing a voltage drop between its terminals in accordance with Ohm's law. This electrical resistance is equal to the voltage drop across the resistor, divided by the current that is flowing through it.
RF/AIS	(Radio Frequency Automatic Identification Systems)
RF/DC	Systems that communicate over a radio link between a host computer and a data source. RF/DC enhances the capabilities of automatic ID Systems by providing the capabilities of hare-wire data communications without the physical restrictions interconnecting wires.
RFID	(Radio Frequency Identification) A method of identifying unique items using radio waves. Typically, a reader communicates with a tag, which holds digital information in a microchip. But there are chipless forms of RFID tags that use material to reflect back a portion of the radio waves beamed at them.

GLOSSARY	
RFID Tags	<p>A system of finding the position or location of assets.</p> <p>A microchip attached to an antenna that is packaged in a way that it can be applied to an object. The tag picks up signals from, and sends signals to, a reader. The tag contains a unique serial number, but may have other information and come in many forms, such as smart labels that can have a barcode printed on it, or can simply be mounted inside a carton or embedded in plastic. RFID tags can be active, passive, or semi-passive.</p> <p>Each tag broadcasts a signal to be received by three reader antennas. The time each signal is received is passed on to a software system that uses triangulation to calculate the location of the asset.</p>
Ribbon	A thin, flexible strip with layers of material; one of which contains ink used to produce an image on print media.
Ribbon Core	A thick cardboard sleeve onto which ribbon is wound.
Rigid	Not flexible - stiff.
ROM	<p>(Read-Only Memory) Also known as firmware, is an integrated circuit programmed with specific data when it is manufactured. There are five basic types: ROM, PROM, EPROM, EEPROM, and Flash Memory.</p> <p>Each type has unique characteristics, but they all are types of memory that have two things in common: the stored data is non-volatile (not lost when power is removed) and the stored data is unchangeable or requires a special operation to do so.</p> <p>ROM chips contain a grid of columns and rows. A diode is used to connect the lines and gain access to the data if the value is 1. If the value is 0, the lines are not connected and access is denied.</p>
RPM	(Revolutions Per Minute) The number of cycles within the time span of one minute.
Route	The path or course taken to get from one location to another - example: the routing of a cable within a machine.
SAM	(Serial Access Memory) Stores data as a series of memory cell that can only be accessed sequentially. Works very well for memory buffers where data is normally stored in the order in which they will be used.
SBPL	(SATO Basic Programming Language)
Scale	<p>The units to measure distance - or a short tool for measurement.</p> <p>To increase or decrease the proportionate size of an object - example: text or graphics on a printed label.</p>
Scanner	In RFID, an antennas transmitter and receiver electronics integrated in a single package.
Screen	An electronic display.
Seat	To nest or couple one object to another. The same as to nest.
Secondary	The next to follow the primary in sequence or importance.
SEMBL	A SATO specific mode of printer operation that can execute the program of BASIC format in the printer. This allows the printer to be configured and operated without interfacing with an external computer or software.
Sensitivity	The degree of ease or difficult to gain a response - example: a sensor transmitter signal may require increase to penetrate the thickness of print media in order to be receipted by its receiver.
Sensor	A device that responds to a physical stimulus and produces and electronic signal.
Separation	The operational distance between two RFID tags.
Sequential	One to follow another in a specified order - examples: 1, 2, 3; A, B, C.
Serial Interface	A general-purpose interface that can be used for almost any type of device in which only 1 bit of communication is transmitted at a time.
Set Screw	Attachment hardware specifically used to secure an object may be moved in a specific position or location.
Shaft	Any rod, bar, or tube.

GLOSSARY	
Simultaneous	To take place at the same time.
Sleeve	A thin hollow material that is inserted onto another to provide proportionate spacing.
Snap Ring	A circular clip that may be applied to a shaft, etc. to prevent another object from moving - used to retain objects in position.
Solid	An item that is not porous.
	An item that is not transparent or translucent.
Spacer	Any object of purpose to maintain a specific distance from two other objects - example: a sleeve or washer.
Spindle	A shaft or rod that is fixed on one or both ends and spins on its axis while maintaining its projection.
SRAM	(Static Random Access Memory) A type of memory that is faster and more reliable than the more common DRAM. The term <i>static</i> is derived from the fact that it doesn't need to be refreshed like DRAM.
Stainless Steel	A shiny, mirror-like carbon steel alloyed with chromium to inhibit rust.
Steel	Metal that contains a specific percentage of carbon. The percentage of carbon determines its strength, in addition to how prone it is to rust.
Stepper Motor	An electrical motor designed to rotate in both directions and to move in incremented distances.
Sub-Assembly	A group of components assembled to form a complete unit that is a part of a larger unit.
Switch	A small mechanical device when altered sends an electrical signal to influence a predetermined activity. Unlike a button or key, switches may have multiple positions.
Tag	Relative to RFID, the transmitter/receiver pair of transceiver plus the information storage mechanism attached to the object. Also referred to as Transponder.
Thermal Transfer	<p>The printing method that creates an image by transferring ink from a heat activated ribbon onto the media using the heat from a thermal printhead.</p> <p>A printhead is composed of a set of pins referred to as "elements" which may be selectively heated through electrical induction. Regular paper media is used in this application in conjunction with the heat sensitive ribbon. The ribbon deposits a coating of dark material onto the paper when exposed to intense heat.</p> <p>Thermal transfer printing is more durable than direct thermal printing and is often used when a label needs to endure longer than a year.</p>
Thermodynamics	The science that deals with the relationship of heat and mechanical energy - also the conversion of one into the other.
Threads	The spiral grooves on the shaft of a screw,
Three-Dimensional	The three projectories of an object: X axis is the distance left and right, the Y axis is the distance up and down, and the Z axis is the distance inward and outward.
Torsion Spring	A piece of wire bent into a spiral and connected on each end by different objects to allow them to be pulled apart and then automatically return to their original position once released.
Transformer	A device used to increase or decrease electricity's voltage and current. The device consists of one or more windings (typically copper) which, the ratio of the number of turns inversely determines the voltage change. The windings are wrapped around a magnetic core affecting magnetic induction.
Transistor	A device used to amplify a signal or open and close a circuit. Is constructed of a semiconductive material and is comprised of three terminals where one can be used to control the flow of current through the other two.
Translucent	When a medium is of a condition so as to allow light to filter.
Transparent	When a medium is of a condition so one can see through it unfettered.
Transponder	Relative to RFID, the transmitter/receiver pair of transceiver plus the information storage mechanism attached to the object. Also referred to as Tag.
Tread	The act of an object making repetitive contact upon another that is in motion.

GLOSSARY	
Troubleshoot	The act of locating the source of a problem or problems.
Two-Dimensional	Two of the projectories of an object: X axis is the distance left and right and the Y axis is the distance up and down. In a two-dimensional perspective, the Z axis is not recognized.
Uniform	The state of multiple objects being the same.
Units	Any fixed quantity, measure, etc.
USB Interface	(Universal Serial Bus) An external peripheral interface standard for communication between a computer and external peripherals over a cable using bi-serial transmission.
Value	The quantity for which a symbol stands.
Vertical	A plane or axis that is plum - the Y axis.
Voltage	The units of electrical force - the ampere current that flows through a conductor.
Volume	The amount of space occupied in three dimensions - cubic contents.
	The strength or loudness of sound.
Washer	A flat disk of metal, rubber, etc., used to make a seat for the head of a bolt, screw, or nut.
Wattage	The amount of electrical power to operate an electrically powered device - arrived by multiplying amperage by voltage.
Wear	To diminish in quality by repetitive activity.
Wireless	Operates with electromagnetic waves and not with conducting wire.
Wiring Harness	Multiple electrical wires bundled together.
X-ON/X-Off	A protocol for controlling the flow of data between computers and other devices on an asynchronous serial connection.
	For example, a computer typically sends data to a printer faster than the printer can print. The printer contains a buffer where data is stored until it catches up, a small microprocessor in the printer sends back an Xoff signal to stop sending data. When enough data is printed and the buffer storage becomes free, the printer sends an Xon signal to resume sending data.